



U.S. Department
of Transportation
**Federal Highway
Administration**

400 Seventh St., S.W.
Washington, D.C. 20590

February 17, 2005

In Reply Refer To: HSA-10/CC-87

Mr. Barry D. Stephens, P.E.
Sr. Vice President Engineering
Energy Absorption Systems, Inc.
3617 Cincinnati Avenue
Rocklin, California 95678

Dear Mr. Stephens:

Your January 28, 2005, letter was recently delivered to Mr. Richard Powers of my staff by Mr. Douglas Bernard. In this letter, you requested formal Federal Highway Administration (FHWA) review and acceptance of a new crash cushion called the QUEST[™]. To support this request, your letter also included a summary report prepared by E-Tech Testing Services that describes the QUEST and the eight full-scale crash tests that were conducted on this attenuator.

The QUEST is a redirective, non-gating crash cushion having an effective length of 5.74 m. It measures 610-mm wide at the backup and stands 813-mm tall. The mass of a fully assembled unit is approximately 600 kg. Its main components, as shown in Enclosure 1, include a ground-anchored backup assembly, two ground-anchored front anchors, two front rails, two rear rails, a nose, a trigger assembly, a sled, a diaphragm, a bridge, and panel assemblies. The panels are fabricated from the American Association of State Highway and Transportation Officials' M-180 Class A (12 GA) w-beam. The nose and diaphragm sheet metal material and thickness designation is ASTM A 569 steel. All other flat bar or plate steel components are made from ASTM A36 steel. The fasteners and anchor/rail connections are specified as SAE J429 GD 8 and all others are SAE J429 GD 5. All components are galvanized per ASTM A123 to resist corrosion. The system can be preassembled and moved to the installation site or can be assembled on-site.

When the QUEST is impacted along the side, the sled, panels and rails go into tension and work together to steer the vehicle away from the hazard. A load-sharing component called the bridge is included in bay 2. The two front rails run the length of the system and are attached at one end to front anchors and at the other to a backup. These rails are supported off the ground at the sled, the diaphragm, and the bridge using guides (3 per side). The sled is secured to the front anchor using 12.7-mm diameter high-strength, all-threaded rods that pass through the



front trigger assembly. During head-on impacts, the trigger mechanism is activated which releases the sled. Longitudinal collision energy is then dissipated through momentum transfer, through the re-shaping the front rails by shapers attached to the sled, through peeling of flat metal plates welded to the inside surface of the panels, and through a second set of shapers incorporated into the backup.

Since the QUEST is a completely new crash cushion, you conducted all eight certification tests recommended in the National Cooperative Highway Research Program (NCHRP) Report 350 for redirecting, non-gating crash cushions. These tests were conducted at test level 3 (TL-3) impact speeds (100 km/h). Tests included 3-30 through 3-33, and 3-36 through 3-39. Each test setup and results are described in your summary report and the one-page test summaries are shown in Enclosure 2. Most were conducted with the unit anchored to concrete, but Tests 3-37 and 3-39 were conducted with the unit anchored to asphalt. When anchored on concrete with a nominal compressive strength of 27.6 MPa., the foundation must be at least 150-mm thick (with reinforced concrete) or 203-mm thick (with no reinforcement). Thirty MP-3 anchors (19-mm diameter, B7, all-thread) with an embedment depth of 140 mm were used for the test series. When anchored to asphalt, the foundation must be at least 150-mm thick over 150-mm thick compacted sub-base and 38 of your MP-3 long-bolts (19-mm diameter, B7, all-thread) are specified with an embedment depth of at least 420 mm.

Tests 3-38 and 3-39 were conducted using a QUEST system equipped with an experimental nose that was later modified. I agree that the nose did not come into play during these two tests and later modifications to the nose would not compromise the results of these tests. I also recognize that the final nose and trigger configuration was validated in Test 3-37, which had an impact point very close to that in Test 3-38. I noted that Test 3-33 was conducted using a QUEST system that incorporated transition hardware to a downstream section of fixed CMB. This worst-case angular impact demonstrated the successful performance of the QUEST when attached to downstream transition hardware. The QUEST system is designed for installation at sites where bi-directional traffic is present. You submitted drawings (Enclosure 3) depicting transitions to w-beam and thrie-beam guardrail as well as New Jersey-shape and vertical concrete walls. I noted that these transitions are virtually identical to those validated in other testing programs previously accepted by the FHWA. Consequently, additional full-scale crash testing is not required for these QUEST transition designs, but, as with all safety hardware, informal field reviews or in-service evaluations are recommended to verify acceptable crash performance.

Your QUEST system meets the evaluation criteria for an NCHRP Report 350 redirective, non-gating crash cushion at TL-3 impact conditions and may be used on the National Highway System (NHS) when such use is acceptable to the contracting authority. The transition designs shown in Enclosure 3 are acceptable when the QUEST is connected to w-beam, thrie-beam, New Jersey- or vertically- faced CMB. Further the QUEST system can be anchored to concrete or asphalt surfaces if these surfaces duplicate the minimum anchoring foundations used in your testing program as noted above.

Please note also that the following provisions apply to the FHWA letters of acceptance:

- This acceptance is limited to the crashworthiness characteristics of the device and does not cover its structural features, nor conformity with the Manual on Uniform Traffic Control Devices.
- Any design changes that may adversely influence the crashworthiness of the device will require a new acceptance letter.
- Should the FHWA discover that the qualification testing was flawed, the in-service performance reveals unacceptable safety problems, or that the device being marketed is significantly different from the version that was crash test, it reserves the right to modify or revoke its acceptance.
- You will be expected to supply potential users with sufficient information on design and installation requirements to ensure proper performance.
- You will be expected to certify to potential users that the hardware furnished has essentially the same chemistry, mechanical properties, and geometry as that submitted for acceptance, and that it will meet the crashworthiness requirements of the NCHRP Report 350.
- To prevent misunderstanding by others, this letter of acceptance, designated as number CC-87, shall not be reproduced except in full. This letter, and test documentation upon which this letter is based, is public information. All such letters and documentation may be reviewed at our office upon request.
- The QUEST is a patented product and is considered proprietary. If proprietary devices are specified by a highway agency for use on a Federal-aid project, except exempt, non-NHS projects, they; (a) must be supplied through competitive bidding with equally suitable unpatented items; (b) the highway agency must certify that they are essential for synchronization with the existing highway facilities or that no equally suitable alternative exists or; (c) they must be used for research or for a distinctive type of construction on relatively short sections of road for experimental purposes. Our regulations concerning proprietary products are contained in Title 23, Code of Federal Regulations, Section 635.411.

Sincerely yours,

/Original Signed by Harry W. Taylor/

~for~

John R. Baxter, P.E.
Director, Office of Safety Design
Office of Safety

3 Enclosures

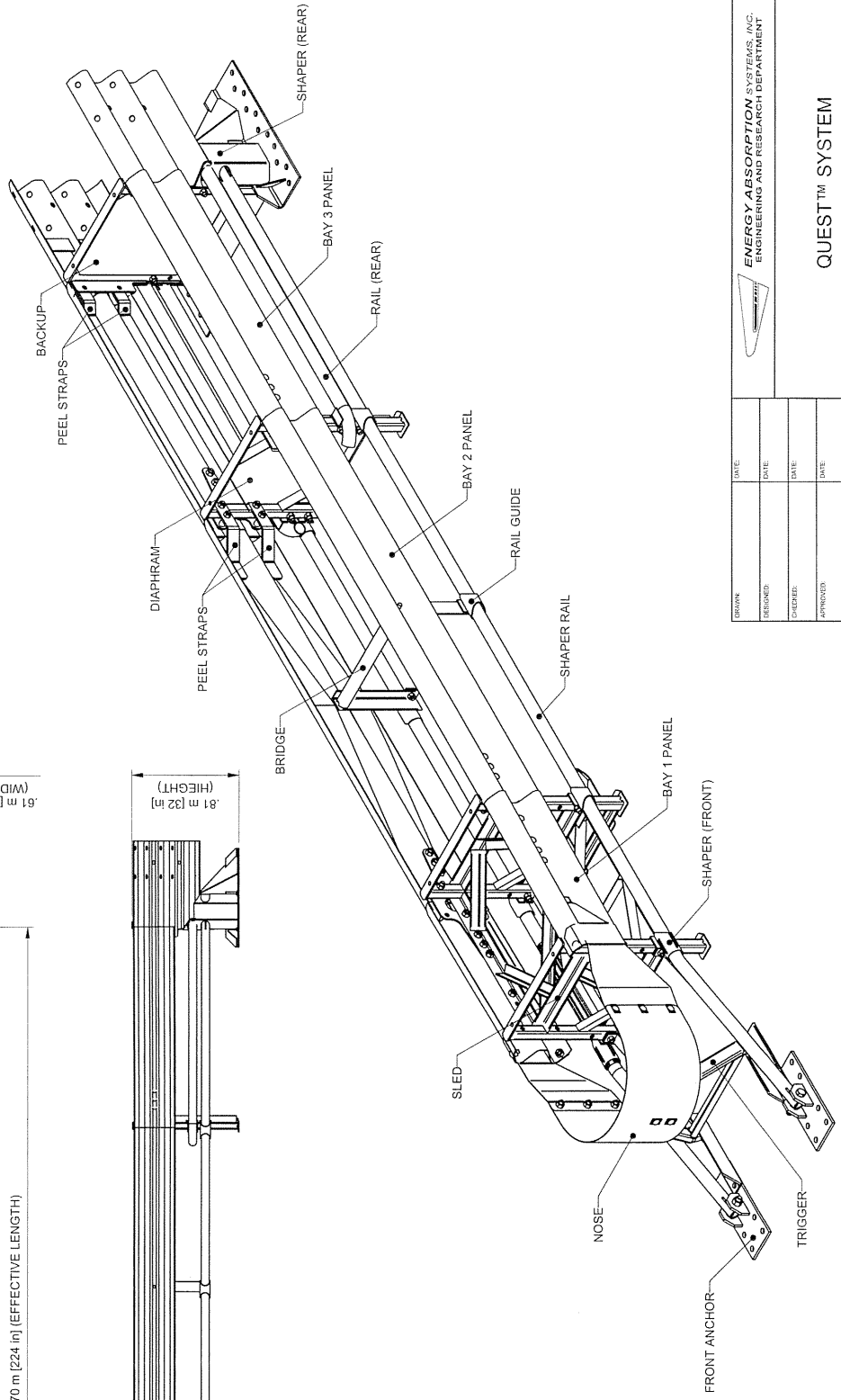
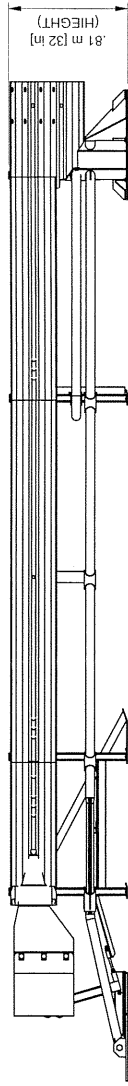
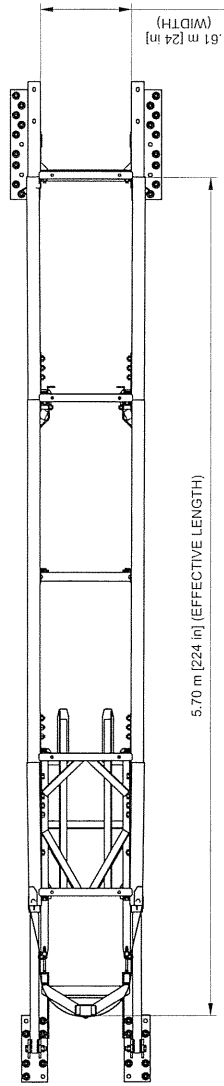

FILE	LC10
SCALE	LC10
DRAWING	LC10
SHEET	1 of 2
REV	

ENERGY ABSORPTION SYSTEMS, INC.
ENGINEERING AND RESEARCH DEPARTMENT

QUEST™ SYSTEM

DATE	
DESIGNED	
CHECKED	
APPROVED	
Q.C.	

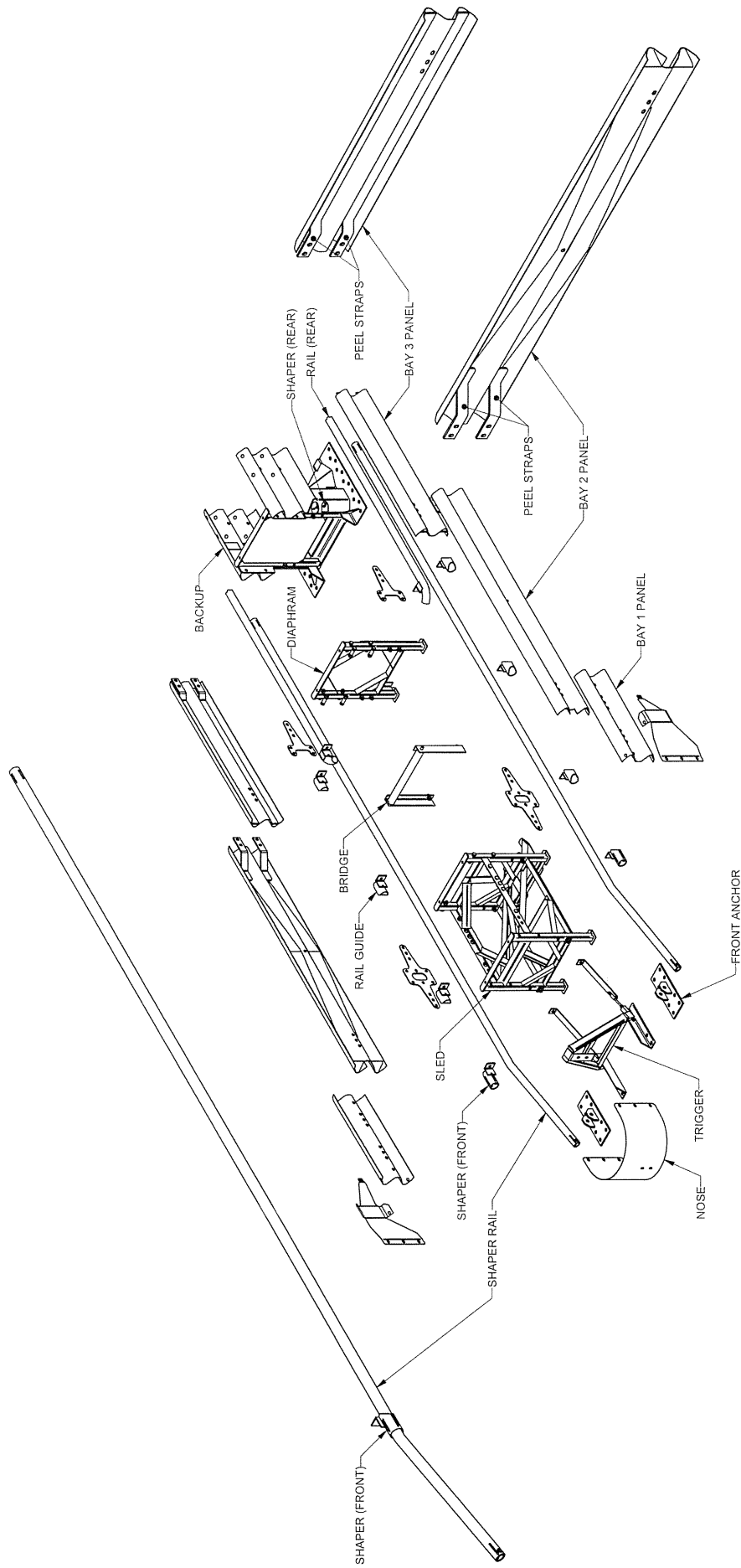

DESIGNED:	DATE:
CHECKED:	DATE:
APPROVED:	DATE:
D.C.	DATE:
FILE NO. LC10	
SCALE	
DRAWING LC10	
SHEET 2 of 2	
REV	

ENERGY ABSORPTION SYSTEMS, INC.
ENGINEERING AND RESEARCH DEPARTMENT

QUEST™ SYSTEM

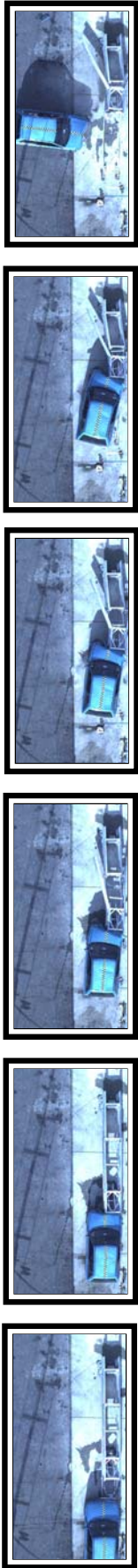

t = 0.680

t = 0.180 sec

t = 0.135 sec

t = 0.090 sec

t = 0.045 sec

t = 0.000 sec

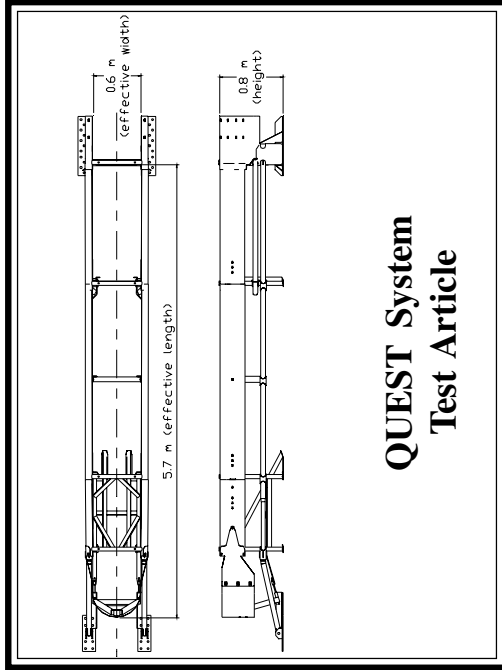

QUEST System Test Article

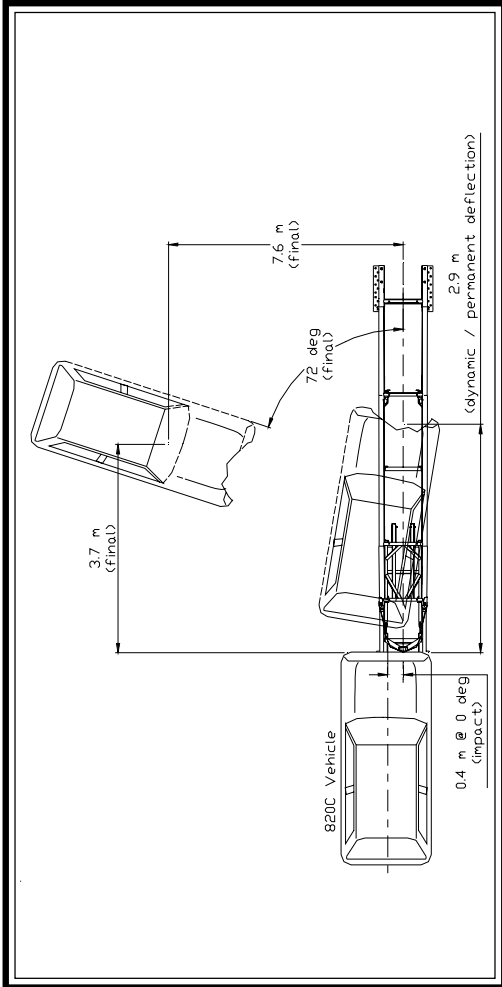

General Information

Test Agency E-TECH Testing Services, Inc.
 Test Designation NCHRP 350 Test 3-30
 Test No. 01-4712-004
 Date 12/9/04
 Test Article
 Type Energy Absorption Systems, Inc.
 QUEST™ System
 Installation Length 5.7 m (effective length)
 Material and key elements AASHTO M180 galvanized steel panels,
 ASTM A500 Rails, and A36 other
 Foundation and Anchoring Unreinforced 27.6 MPa concrete,
 clean and dry with (30) 19 mm x 178 mm
 ASTM A193 Grade B-7 threaded studs and
 MP-3 Anchoring System

Test Vehicle

Type
 Designation 820C
 Model 1990 Ford Festiva

Mass (kg)
 Curb 801
 Test inertial 818
 Dummy 75
 Gross 893

Impact Conditions

Speed (km/h) 98.3
 Angle (deg) 0
 Impact Severity (kJ) 305.1

Exit conditions

Speed (km/h) N/A
 Angle (deg - veh. c.g.) N/A

Occupant Risk Values

Impact Velocity (m/s)
 x-direction 11.6
 y-direction -0.2

Ridedown Acceleration (g's)

x-direction -20.3
 y-direction 5.4

European Committee for Normalization (CEN) Values

THIV (km/h) 42.0
 PHD (g's) 20.3
 ASI 1.4

Test Article Deflections (m)

Dynamic 2.9
 Permanent 2.9

Vehicle Damage (Primary Impact)

Exterior
 VDS FR-4
 CDC I2FERW4

Interior

VCDI AS0000000
 Maximum Deformation (mm) 35

Post-Impact Vehicular Behavior (deg - rate gyro)

Maximum Roll Angle 11.9
 Maximum Pitch Angle -19.9
 Maximum Yaw Angle 107.4

Figure 1. Summary of Results - QUEST NCHRP 350 Test 3-30



t = 0.000 sec t = 0.057 sec t = 0.114 sec t = 0.171 sec t = 0.450 sec

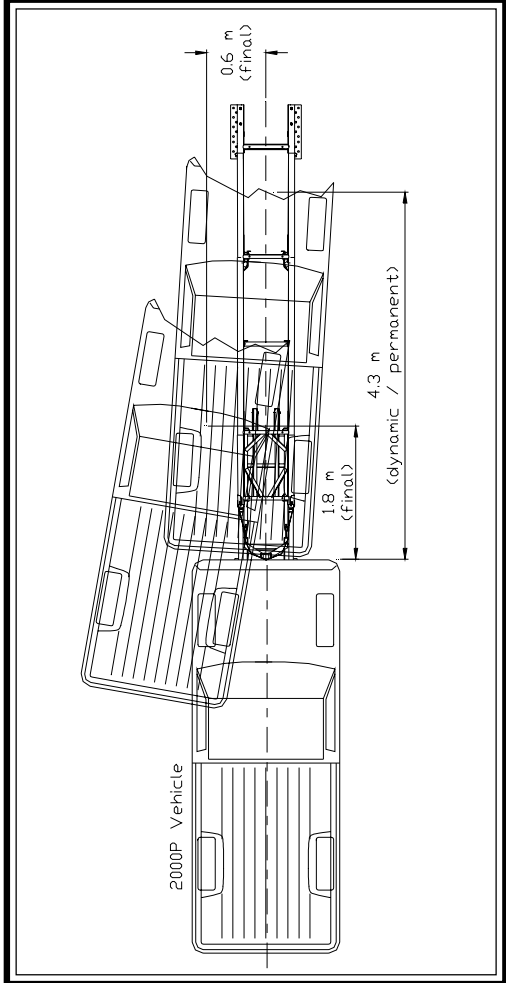
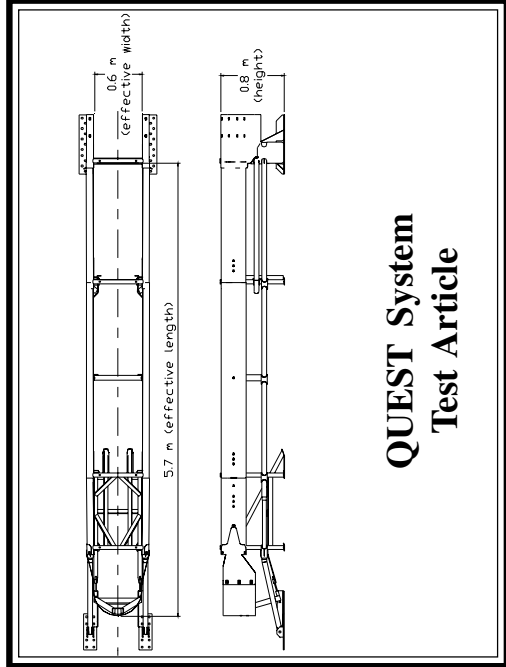

QUEST System Test Article

General Information	
Test Agency	E-TECH Testing Services, Inc.
Test Designation	NCHRP 350 Test 3-31
Test No.	01-4712-005
Date	1/6/05
Test Article	
Type	Energy Absorption Systems, Inc. QUEST™ System
Installation Length	5.7 m (effective length)
Material and key elements	AASHTO M180 galvanized steel panels, ASTM A500 Rails, and A36 other clean and dry with (30) 19 mm x 178 mm ASTM A193 Grade B-7 threaded studs and MP-3 Anchoring System
Test Vehicle	
Type	Production Model
Designation	2000P
Model	1991 Chevrolet C2500
Mass (kg)	
Curb	1859
Test inertial	2024
Dummy	N/A
Gross	2024
Impact Conditions	
Speed (km/h)	101.8
Angle (deg)	0
Impact Severity (kJ)	808.5
Exit conditions	
Speed (km/h)	N/A
Angle (deg - veh. c.g.)	N/A
Occupant Risk Values	
Impact Velocity (m/s)	
x-direction	9.6
y-direction	-0.5
Ridedown Acceleration (g's)	
x-direction	-19.9
y-direction	4.5
European Committee for Normalization (CEN) Values	
PHD (g's)	34.4
THIV (km/h)	19.9
ASI	1.4
Test Article Deflections (m)	
Dynamic	4.3
Permanent	4.3
Vehicle Damage (Primary Impact)	
Exterior	
VDS	FC-4
CDC	12FCEW4
Interior	
VCDI	AS0000000
Maximum Deformation (mm)	30
Post-Impact Vehicular Behavior (deg - rate gyro)	
Maximum Roll Angle	5.3
Maximum Pitch Angle	-10.5
Maximum Yaw Angle	10.0

General Information	
Test Agency	E-TECH Testing Services, Inc.
Test Designation	NCHRP 350 Test 3-31
Test No.	01-4712-005
Date	1/6/05
Test Article	
Type	Energy Absorption Systems, Inc. QUEST™ System
Installation Length	5.7 m (effective length)
Material and key elements	AASHTO M180 galvanized steel panels, ASTM A500 Rails, and A36 other clean and dry with (30) 19 mm x 178 mm ASTM A193 Grade B-7 threaded studs and MP-3 Anchoring System
Test Vehicle	
Type	Production Model
Designation	2000P
Model	1991 Chevrolet C2500
Mass (kg)	
Curb	1859
Test inertial	2024
Dummy	N/A
Gross	2024
Impact Conditions	
Speed (km/h)	101.8
Angle (deg)	0
Impact Severity (kJ)	808.5

Figure 6. Summary of Results - QUEST NCHRP 350 Test 3-31



t = 0.000 sec

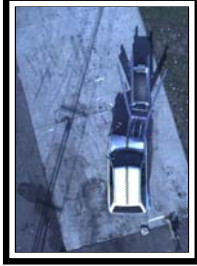

t = 0.046 sec



t = 0.092 sec



t = 0.138 sec



t = 0.184 sec



t = 0.450 sec

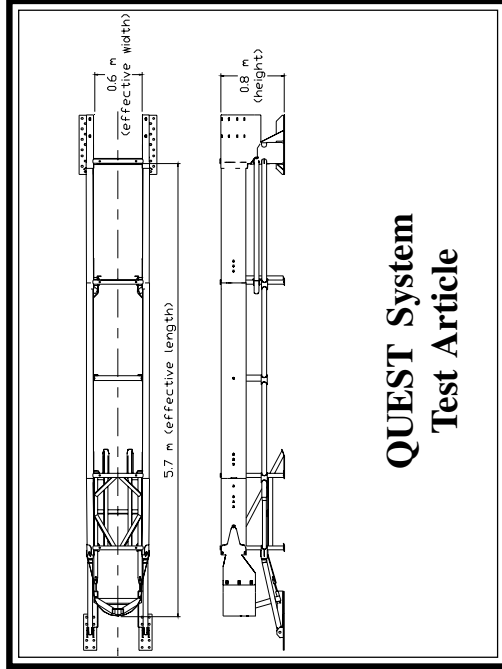
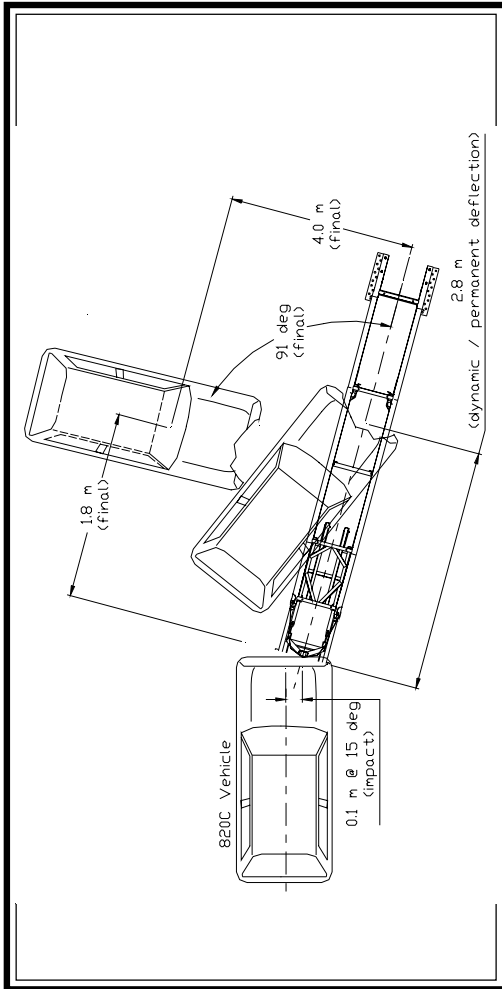

QUEST System Test Article

General Information

Test Agency E-TECH Testing Services, Inc.
 Test Designation NCHRP 350 Test 3-32
 Test No. 01-4712-003
 Date 12/3/04

Test Article

Type Energy Absorption Systems, Inc.
 QUEST™ System
 Installation Length 5.7 m (effective length)
 Material and key elements AASHTO M180 galvanized steel panels, ASTM A500 Rails, and A36 other
 Foundation and Anchoring Unreinforced 27.6 MPa concrete, clean and dry with (30) 19 mm x 178 mm ASTM A193 Grade B-7 threaded studs and MP-3 Anchoring System

Test Vehicle

Type 820C
 Designation 1988 Ford Festiva
 Model
 Mass (kg)
 Curb 801
 Test inertial 820
 Dummy 75
 Gross 895

Impact Conditions

Speed (km/h) 99.0
 Angle (deg) 15
 Impact Severity (kJ) 310.0

Exit conditions
 Speed (km/h) N/A
 Angle (deg - veh. c.g.) N/A
 Occupant Risk Values
 Impact Velocity (m/s)
 x-direction 11.2
 y-direction 0.7
 Ridedown Acceleration (g's)
 x-direction -20.1
 y-direction 6.8
 European Committee for Normalization (CEN) Values
 THIV (km/h) 40.6
 PHD (g's) 20.1
 ASI 1.5
 Test Article Deflections (m)
 Dynamic 2.8
 Permanent 2.8
 Vehicle Damage (Primary Impact)
 Exterior
 VDS FC-4
 CDC 12FCEW4
 Interior
 VCDI AS0000000
 Maximum Deformation (mm) 38
 Post-Impact Vehicular Behavior (deg - rate gyro)
 Maximum Roll Angle 15.8
 Maximum Pitch Angle -24.9
 Maximum Yaw Angle 103.7

Figure 11. Summary of Results - QUEST NCHRP 350 Test 3-32



t = Final

t = 0.300 sec

t = 0.225 sec

t = 0.150 sec

t = 0.075 sec

t = 0.000 sec

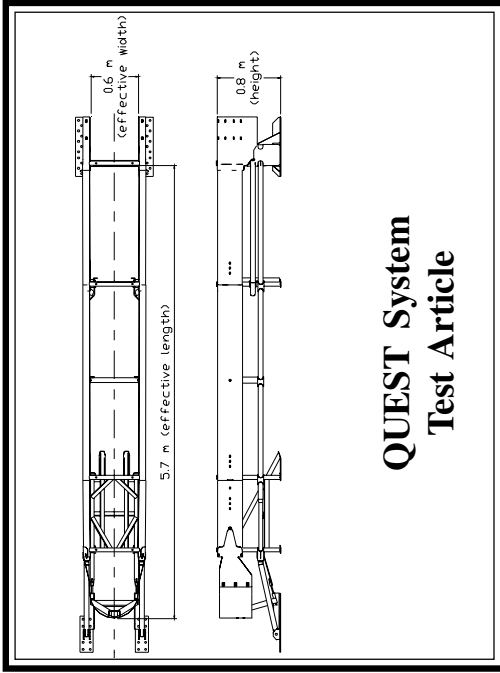

QUEST System Test Article

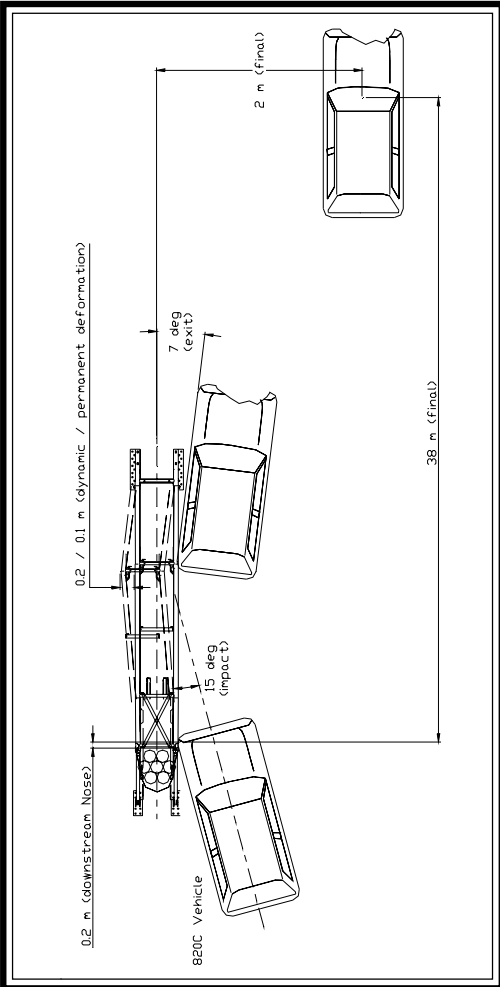

General Information

Test Agency E-TECH Testing Services, Inc.
 Test Designation NCHRP 350 Test 3-36
 Test No. 01-4712-008
 Date..... 1/21/05

Test Article
 Type Energy Absorption Systems, Inc.
 QUEST™ System

Installation Length 5.7 m (effective length)
 Material and key elements AASHTO M180 galvanized steel panels,
 ASTM A500 Rails, and A36 other
 Foundation and Anchoring Unreinforced 27.6 MPa concrete,
 clean and dry with (30) 19 mm x 178 mm
 ASTM A193 Grade B-7 threaded studs and
 MP-3 Anchoring System

Test Vehicle

Type Production Model
 Designation 820C
 Model 1989 Ford Festiva
 Mass (kg)
 Curb 798
 Test inertial 810
 Dummy 75
 Gross 885

Impact Conditions

Speed (km/h) 99.7
 Angle (deg) 15
 Impact Severity (kJ) 22.7

Exit conditions

Speed (km/h) 89
 Angle (deg - veh. c.g.) 7

Occupant Risk Values
 Impact Velocity (m/s)
 x-direction 2.1
 y-direction 5.7

Ridedown Acceleration (g/s)
 x-direction -4.1
 y-direction 11.0

European Committee for Normalization (CEN) Values
 THIV (km/h) 22.4
 PHD (g/s) 11.1
 ASI 0.7

Test Article Deflections (m)
 Dynamic 0.2
 Permanent 0.1

Vehicle Damage (Primary Impact)
 Exterior 11FEW2
 Interior AS000000
 VCDI Negligible
 Maximum Deformation (mm)
 Post-Impact Vehicular Behavior (deg - rate gyro)
 Maximum Roll Angle 7.4
 Maximum Pitch Angle 12.8
 Maximum Yaw Angle 19.7

Figure 21. Summary of Results - QUEST NCHRP 350 Test 3-36



t = 0.000 sec

t = 0.100 sec

t = 0.200 sec

t = 0.300 sec

t = 0.400 sec

t = Final

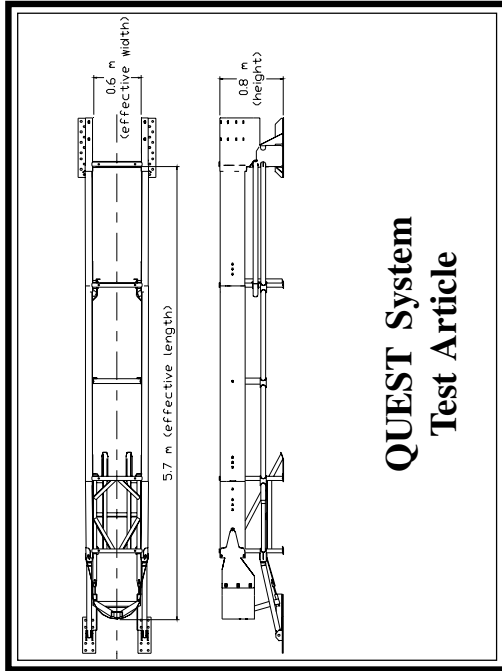
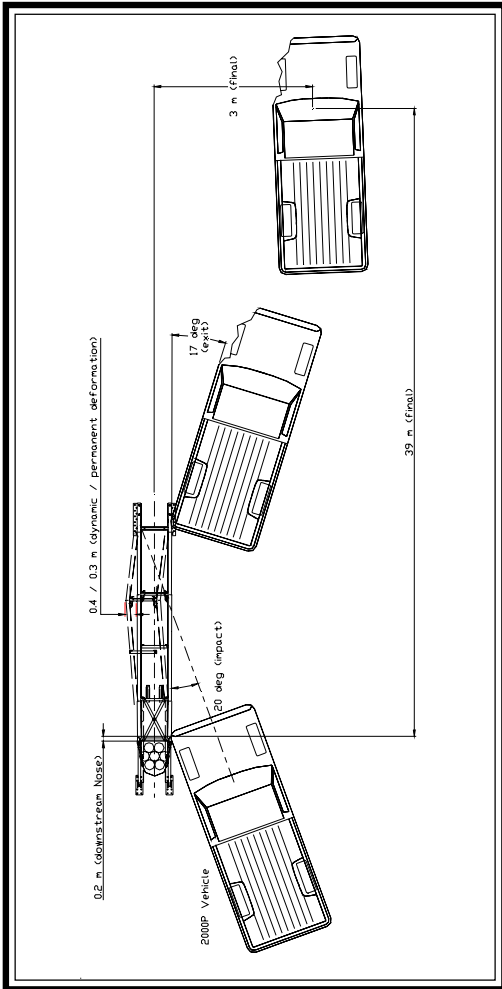

QUEST System Test Article

General Information

Test Agency E-TECH Testing Services, Inc.
 Test Designation NCHRP 350 Test 3-37
 Test No. 01-4712-007
 Date 1/19/05
 Test Article Type Energy Absorption Systems, Inc. QUEST™ System
 Installation Length 5.7 m (effective length)
 Material and key elements AASHTO M180 galvanized steel panels, ASTM A500 Rails, and A36 other
 Foundation and Anchoring 150 mm thick asphalt over 200 mm aggregate base with (38) 19 mm x 457 mm ASTM A193 B7 threaded rods
 MP-3 Asphalt Anchoring System

Test Vehicle

Type Production Model
 Designation 2000P
 Model 1994 GMC
 Mass (kg)
 Curb 1921
 Test inertial 1998
 Dummy N/A
 Gross 1998
 Impact Conditions
 Speed (km/h) 99.7
 Angle (deg) 20
 Impact Severity (kJ) 89.6
 Exit conditions
 Speed (km/h) 73
 Angle (deg - veh. c.g.) 17

Occupant Risk Values
 Impact Velocity (m/s)
 x-direction 4.0
 y-direction 6.4
 Ridedown Acceleration (g's)
 x-direction -10.8
 y-direction 15.3
 European Committee for Normalization (CEN) Values
 THIV (km/h) 26.5
 PHD (g's) 17.5
 ASI 1.2
 Test Article Deflections (m)
 Dynamic 0.4
 Permanent 0.3
 Vehicle Damage (Primary Impact)
 Exterior
 VDS LFQ-4
 CDC LIFDEW3
 Interior
 VCDI AS0000000
 Maximum Deformation (mm) 30
 Post-Impact Vehicular Behavior (deg - rate gyro)
 Maximum Roll Angle -27.8
 Maximum Pitch Angle -16.4
 Maximum Yaw Angle 42.7

Figure 26. Summary of Results - QUEST NCHRP 350 Test 3-37



t = 0.000 sec



t = 0.096 sec



t = 0.192 sec



t = 0.288 sec



t = 0.384 sec



t = Final

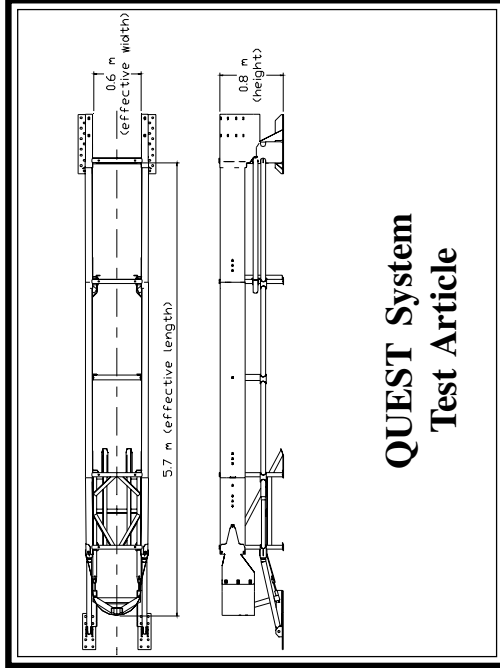
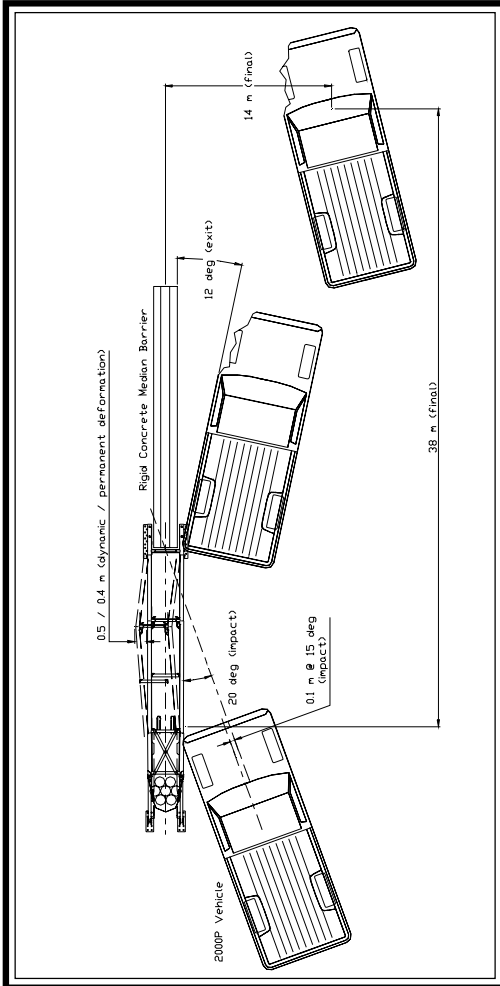

QUEST System Test Article

General Information

Test Agency	E-TECH Testing Services, Inc.
Test Designation	NCHRP 350 Test 3-38
Test No.	01-4712-001
Date	8/24/04
Test Article Type	Energy Absorption Systems, Inc. QUEST™ System
Installation Length	5.7 m (effective length)
Material and key elements	AASHTO M180 galvanized steel panels, ASTM A500 Rails, and A36 other Unreinforced 27.6 MPa concrete, clean and dry with (30) 19 mm x 178 mm ASTM A193 Grade B-7 threaded studs and MP-3 Anchoring System
Foundation and Anchoring	
Test Vehicle Type	Production Model
Designation	2000P
Model	1989 Chevrolet C2500
Mass (kg) Curb	1906
Test inertial	2014
Dummy	N/A
Gross	2014
Impact Conditions Speed (km/h)	100.4
Angle (deg)	20
Impact Severity (kJ)	91.5
Exit conditions Speed (km/h)	78
Angle (deg - veh. c.g.)	12

Occupant Risk Values*	
Impact Velocity (m/s)	
x-direction	7.1
y-direction	6.2
Ridedown Acceleration (g's)	
x-direction	11.5**
y-direction	13.3
European Committee for Normalization (CEN) Values	
THIV (km/h)	35.4
PHD (g's)	19.2
ASI	1.1
Test Article Deflections (m)	
Dynamic	0.5
Permanent	0.4
Vehicle Damage (Primary Impact)	
Exterior	
VDS	LFQ-4
CDC	11FDEW3
Interior	
VCDI	LF0010000
Maximum Deformation (mm)	15
Post-Impact Vehicular Behavior (deg - rate gyro)	
Maximum Roll Angle	-23.5
Maximum Pitch Angle	-8.3
Maximum Yaw Angle	39.3

* Primary data lost due to switch failure, backup data reported.
 **The maximum negative acceleration (deceleration) was -9.0 g's

Figure 31. Summary of Results - QUEST NCHRP 350 Test 3-38



t = 0.000 sec



t = 0.070 sec



t = 0.140 sec



t = 0.210 sec



t = 0.280 sec



t = 0.455 sec

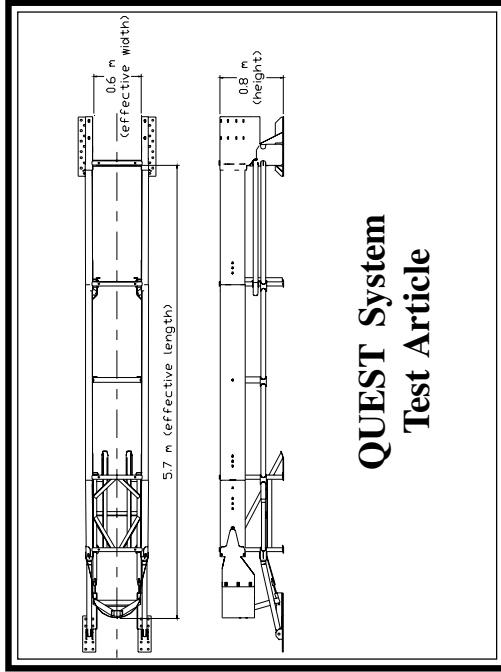
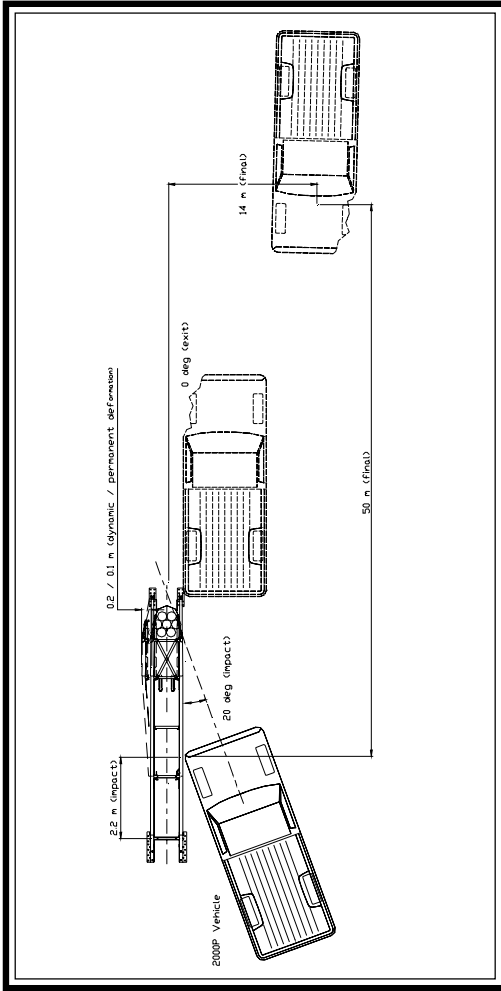

General Information

Test Agency
 Test Designation
 Test No.
 Date
 Test Article
 Type
 Installation Length
 Material and key elements
 Foundation and Anchoring
 Test Vehicle
 Type
 Designation
 Model
 Mass (kg)
 Curb
 Test Inertial
 Dummy
 Gross
 Impact Conditions
 Speed (km/h)
 Angle (deg)
 Impact Severity (kJ)

E-TECH Testing Services, Inc.
 NCHRP 350 Test 3-39
 01-4712-002
 9/24/04

Energy Absorption Systems, Inc.
 QUEST™ System
 5.7 m (effective length)
 AASHTO M180 galvanized steel panels,
 ASTM A500 Rails, and A36 other
 150 mm thick asphalt over 200 mm
 aggregate base with (38) 19 mm x 457 mm
 ASTM A193 B7 threaded rods
 MP-3 Asphalt Anchoring System

Production Model
 2000P
 1990 Chevrolet C2500
 1875
 2005
 N/A
 2005
 99.7
 20
 89.9

Exit conditions
 Speed (km/h)
 Angle (deg - veh. c.g.)

Occupant Risk Values

Impact Velocity (m/s)
 x-direction
 y-direction
 Ridedown Acceleration (g's)
 x-direction
 y-direction
 European Committee for Normalization (CEN) Values
 THIV (km/h)
 PHD (g's)
 ASI

Test Article Deflections (m)

Dynamic
 Permanent
 Vehicle Damage (Primary Impact)
 Exterior
 VDS
 CDC
 Interior
 VCDI

Maximum Deformation (mm)
 Post-Impact Vehicular Behavior (deg - rate gyro)
 Maximum Roll Angle
 Maximum Pitch Angle
 Maximum Yaw Angle

Figure 36. Summary of Results - QUEST NCHRP 350 Test 3-39

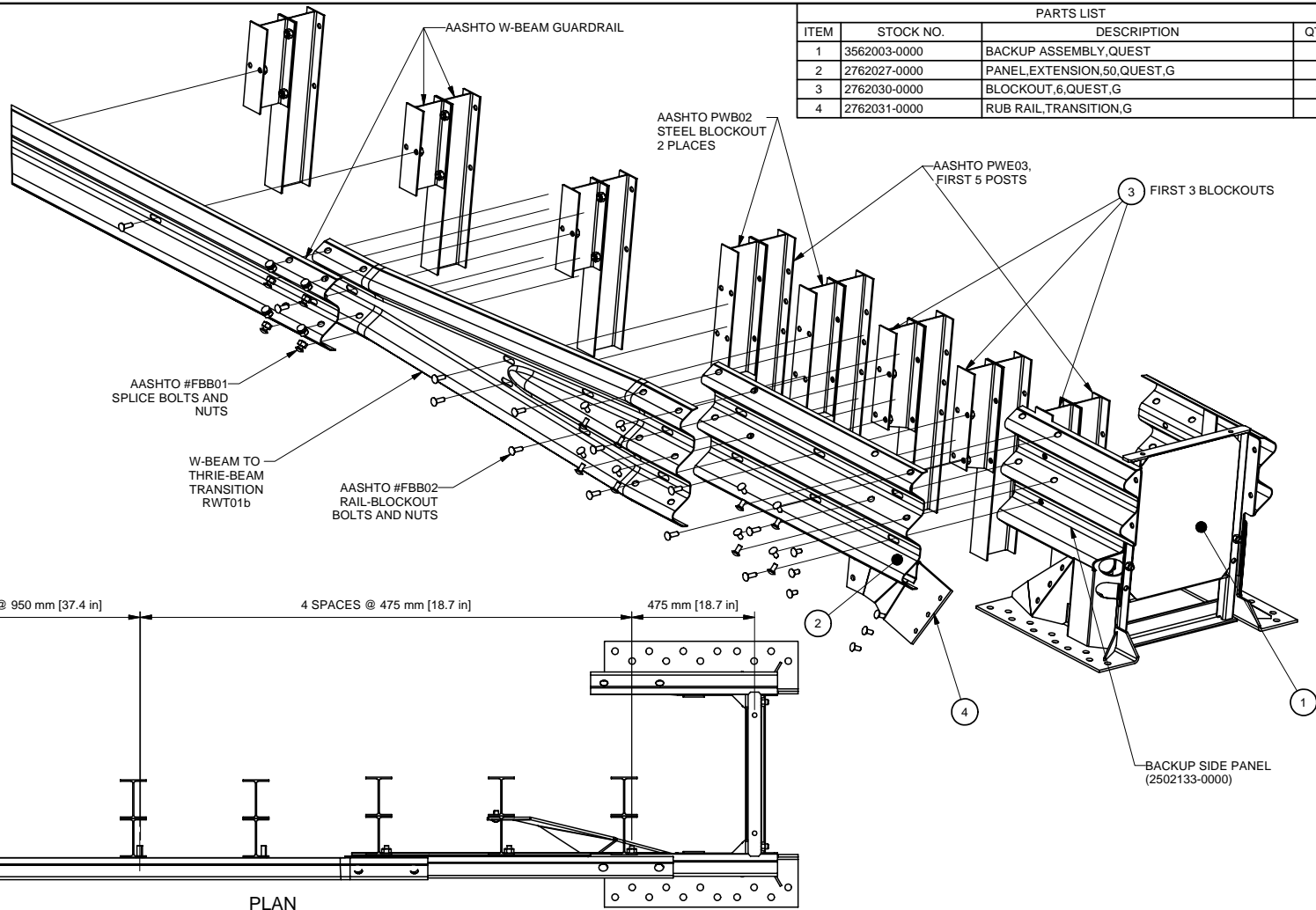

PARTS LIST			
ITEM	STOCK NO.	DESCRIPTION	QTY.
1	3562003-0000	BACKUP ASSEMBLY,QUEST	1
2	2762027-0000	PANEL,EXTENSION,50,QUEST,G	1
3	2762030-0000	BLOCKOUT,6,QUEST,G	3
4	2762031-0000	RUB RAIL,TRANSITION,G	1

STANDARD W-BEAM GUARDRAIL

4 SPACES @ 950 mm [37.4 in]

4 SPACES @ 475 mm [18.7 in]

475 mm [18.7 in]

PLAN

DRAWN:	DATE:
DESIGNED:	DATE:
CHECKED:	DATE:
APPROVED:	DATE:
FILE: 3526011.idw	
NEXT ASSEMBLY:	



TRANSITION ASSY,THRIE-W,QUEST

SCALE:	DRAWING: 3526011	SHEET: 1 of 1	REV:
--------	------------------	---------------	------

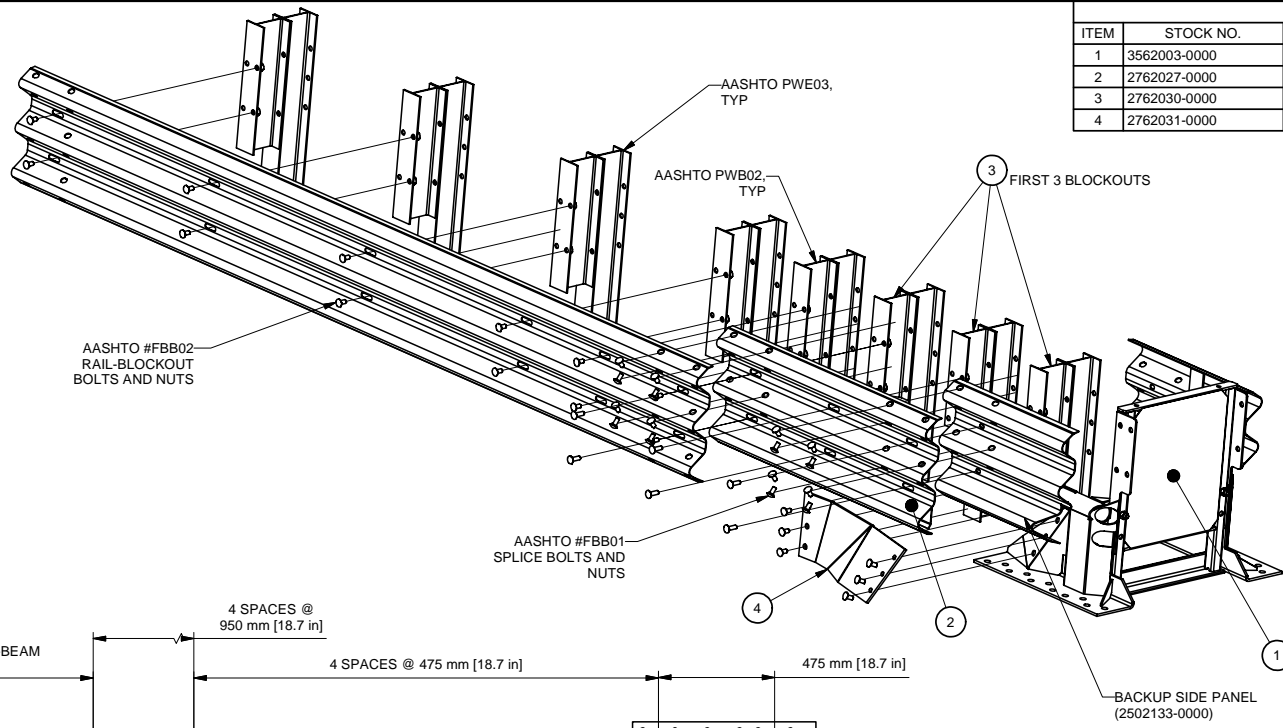

PARTS LIST			
ITEM	STOCK NO.	DESCRIPTION	QTY.
1	3562003-0000	BACKUP ASSEMBLY,QUEST	1
2	2762027-0000	PANEL,EXTENSION,50,QUEST,G	1
3	2762030-0000	BLOCKOUT,6,QUEST,G	3
4	2762031-0000	RUB RAIL,TRANSITION,G	1

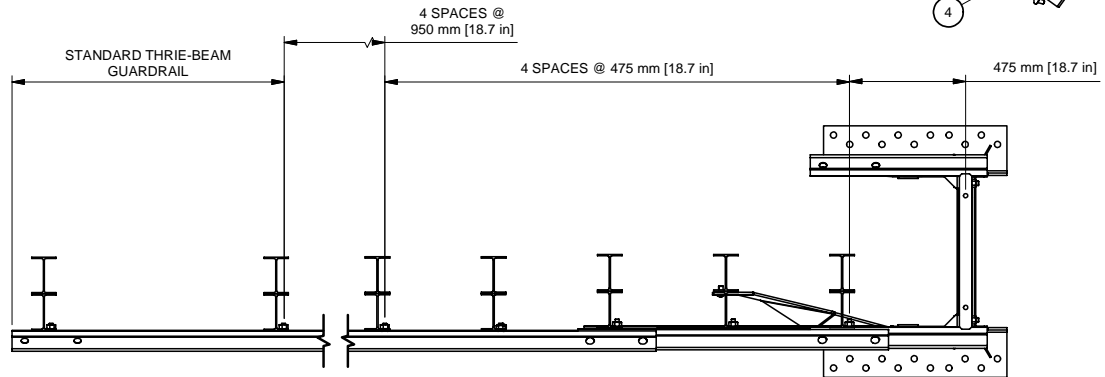

PLAN

	DRAWN:	DATE:
	DESIGNED:	DATE:
	CHECKED:	DATE:
	APPROVED:	DATE:
	FILE: 3526010.idw	
NEXT ASSEMBLY:		



TRANSITION ASSY,THRIE,QUEST

SCALE:	DRAWING: 3526010	SHEET: 1 of 1	REV:
--------	------------------	---------------	------

PARTS LIST			
ITEM	STOCK NO.	DESCRIPTION	QTY.
1	2762029-0000	BRACKET,TRANS SUP,5,ANG,QUEST,G	1
2	3562003-0000	BACKUP ASSEMBLY,QUEST	1
3	2762027-0000	PANEL,EXTENSION,50,QUEST,G	1
4	2762028-0000	BRACKET,TRANS SUPPORT,9,QUEST,G	3
5		PANEL,TRANSITION,9 OFFSET,L,G	1

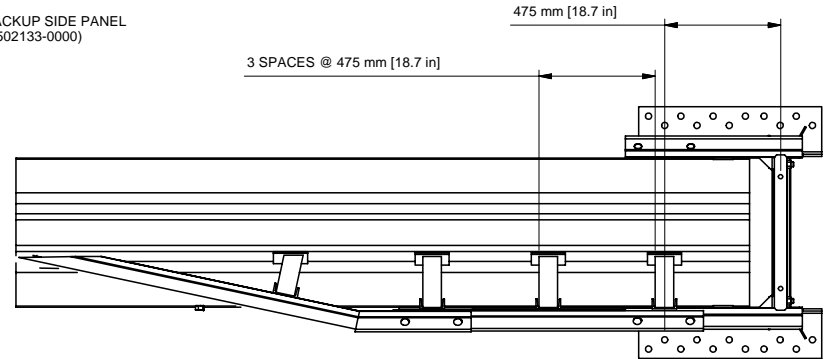
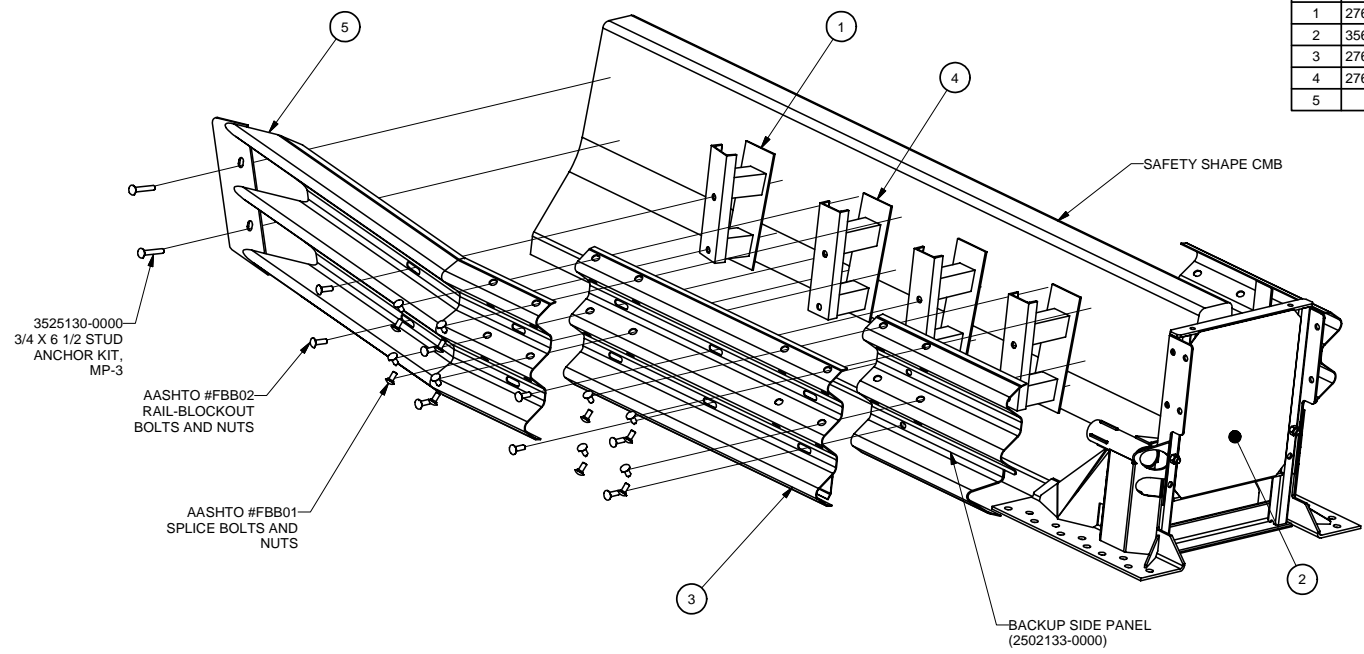

PLAN

DRAWN:	DATE:
DESIGNED:	1/27/2005
CHECKED:	DATE:
APPROVED:	DATE:
FILE:	356209L.idw
NEXT ASSEMBLY:	



ENERGY ABSORPTION SYSTEMS, INC.
 ENGINEERING AND RESEARCH DEPARTMENT

TRANSITION ASSY,9 OFFSET,L,QUEST

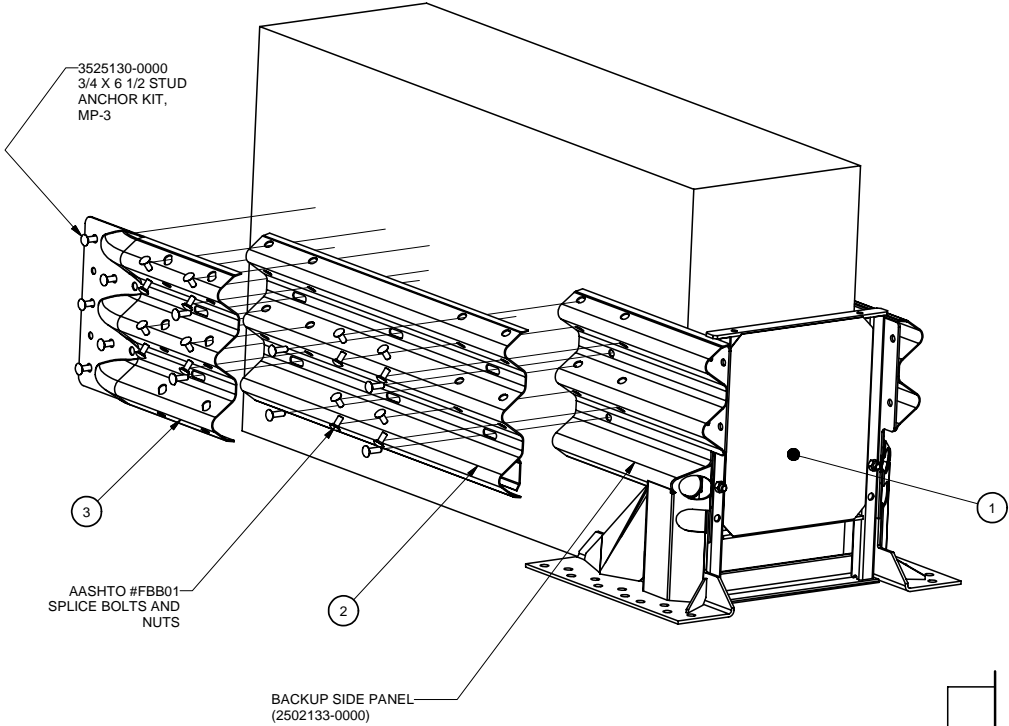
SCALE:	DRAWING: 356209L	SHEET: 1 of 1	REV
--------	------------------	---------------	-----

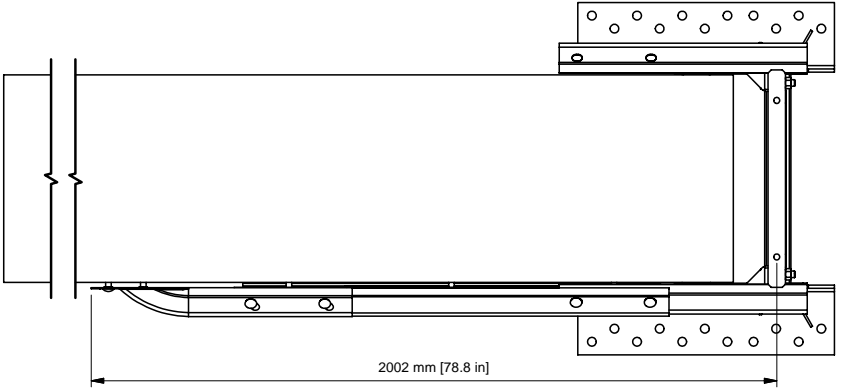

PARTS LIST			
ITEM	STOCK NO.	DESCRIPTION	QTY.
1	3562003-0000	BACKUP ASSEMBLY,QUEST	1
2	2762027-0000	PANEL,EXTENSION,50,QUEST,G	1
3	2752431-0000	END SHOE,THRIE BEAM	1



PLAN

DRAWN: DESIGNED: CHECKED: APPROVED: FILE: 3526012.idw NEXT ASSEMBLY:	DATE:	1/27/2005		TRANSITION ASSY,THRIE-ENDSHOE,QUEST	
	DATE:				
	DATE:				
	DATE:				
	DATE:				
SCALE:	DRAWING:	3526012	SHEET:	1 of 1	REV: