



U.S. Department  
of Transportation

**Federal Highway  
Administration**

MAY 30 1990

400 Seventh St., S.W.  
Washington, D.C. 20590

Refer to: HNG-14

Hr. Robert A. Sik  
Vice President, Akron Foundry Company  
2728 Wingate Avenue  
P. O. 80x 27028  
Akron, Ohio 44319-0009

Dear Mr. Sik:

Thank you for your April 20 letter requesting revisions to our previous acceptance of your TB-1 and TB-2 cast aluminum breakaway transformer bases for use on Federal-aid highway projects. Our January 12, 1989, letter accepted your company's TB-1 transformer base with a maximum pole weight of 832 pounds. Our January 24, 1990, letter accepted your company's TB-2 transformer base with a **10.5-inch** maximum bolt circle limitation. Your April 20 letter referenced two Southwest Research Institute (SwRI) reports (Project No. 06-3116-516, Test 9 and Test 1) dated April 1990, containing e results of pendulum tests on a TB-1 base supporting a 950-pound pole, and a TB-2 base mounted on a 12-inch diameter bolt circle, the maximum for which this base was designed. The tests were conducted to assess the compliance of these pole and base combinations with the Federal Highway Administration (FHWA) breakaway requirements, which cite Section 7 of the 1985 American Association of State Highway and Transportation Officials' (AASHTO) Standard Specifications for Structural Supports for Highway Signs, Luminaires and Traffic Signals.

The tests used an instrumented **1,800-pound** pendulum fitted with a 10 stage crushable nose, which simulates a 1979 Volkswagen Rabbit. Measured and extrapolated results of the tests, referenced as "Series III," are summarized in enclosure number 1. (Previous tests of Akron Foundry transformer bases are also shown on this enclosure as Test Series I and II.) The reported stub heights were 3.3 inches which is the measurement to the top of the anchor bolt.. In both tests, a shard of aluminum from the transformer base remained in place to a height of 6.0 or 6.7 inches. We concur with the SwRI conclusion that these protrusions above the 4-inch maximum do **not constitute** "substantial remains" as referred to in Section 7 of the AASHTO specifications.

The 16.7 fps calculated change in velocity of Test 9 using the TB-1 exceeds FHWA requirements by 0.7 fps. However, as the evidence you presented in your submission indicates, the calculated changes in velocities nearly always over estimate the 60-mph results. Therefore, we will consider the results as meeting the new FHWA requirements.

In both tests machined washers were used on the bolts attaching the bottom of the base to the test pad. As these smoother surfaced washers develop less friction than typical galvanized ones, the breakaway performance may have been enhanced. Thus, our acceptance is limited to the use of similarly machined washers for the use with the anchor bolts. We also note that the nuts on the anchor bolts were tightened using an air impact wrench. The SwRI estimates that the torque values are in the range of 190 to 215 foot-pounds. Our acceptance, therefore, is further conditioned by limiting the torque of the anchor bolt nuts to 200 foot-pounds.

In Test-9 and all the Series I tests of the TB-1 base, 1-inch diameter anchor bolts were used. Our January 12, 1989, letter accepted the TB-1 for use "within the range of conditions tested." Your drawings of the TB-1 bases permit a 1 1/4-inch diameter anchor bolt. The use of larger fasteners than those used in the tests is considered to be outside of the range of conditions tested and is, therefore, not acceptable for use on Federal-aid highway projects without further testing.

The above information shows that the test results of the subject pole and base combinations can be considered as meeting the change in velocity and stub-height requirements adopted by the FHWA. Thus, TB-1 bases with poles weighing up to 950 pounds and having a bottom bolt circle of up to 15.0 inches using 1-inch bolts torqued to a maximum of 200 foot-pounds, and TB2 bases with poles weighing up to 550 pounds and having a bottom bolt circle diameter up to 12.0 inches, as shown on enclosures 2 and 3, are acceptable for use on Federal-aid highway projects if proposed by a State.

Our acceptance is limited to the breakaway characteristics of the bases and does not cover their structural features. Presumably, you will supply potential users with sufficient information on structural design and installation requirements to ensure proper performance. We anticipate that the States will require certification from Akron Foundry Company that the castings furnished have essentially the same chemistry, mechanical properties, and geometry as the casting used in the relevant test, and that the castings will meet the FHWA change in velocity requirements.

Since your company's breakaway support designs are proprietary items, to be used in a Federal-aid highway project they; (a) must be supplied through competitive bidding with equally suitable unpatented items; (b) the State highway agency must certify that they are essential for synchronization with existing highway facilities, or that no equally suitable alternate exists; or (c) they must be used for research or for a distinctive type of construction

on relatively short sections of road for experimental purposes. Our regulations concerning proprietary products are contained in Title 23, Code of Federal Regulations, Section 635.411, a copy of which is provided as enclosure 4 for your information.

Sincerely yours,

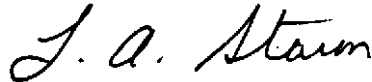

**L. A. Staron**

Chief, Federal-Aid and Design Division

Enclosures

Endorsement to FHWA Field Offices:

Geometric and Roadside Design acceptance letter number LS-15

The cast aluminum transformer base Akron Foundry TB-1 is nominally the same as the Valmont part number 0283093 base which is the subject of a same-dated letter to Dennis O'Brien of Valmont Industries (Geometric and Roadside Design Acceptance letter LS-14). The TB-1 base was also the subject of letters to Akron Foundry dated **6/29/88** (LS-2) and **1/12/89** (LS-4).

| Test Series | Test Number | Base Number | Test Delta @ 20moh (fpsj) | Calc'd Delta V @ 60moh (fps) | Stub Height (in.) W/arm & Dummy (pounds) | Pole Uei ght | Pole Type | Nanial Luminaire Mounting Height (feet) | Mast Arm Length (ft) | Base Bottom Bolt Circle Diameter (in.) | Bottom Bolt Diameter (in.) | Bottom Washer Outside Diameter (in.) | Bottom Uasher Thick- ness (in.) | Base Top Bolt Circle Diameter (in.) | Top Bolt Diameter (in.) | Top Yasher Diameter (in.) | Top Washer Thick- ness (in.) |      |      |       |       |      |      |       |     |      |      |       |     |
|-------------|-------------|-------------|---------------------------|------------------------------|--|--------------|-----------|---|----------------------|--|----------------------------|--------------------------------------|---------------------------------|-------------------------------------|-------------------------|---------------------------|------------------------------|------|------|-------|-------|------|------|-------|-----|------|------|-------|-----|
| I           | 11          | TB-1AF      | 1315-17                   | 1315-17                      | I.W.                                     | 6.19         | 7.17      | 10.23                                   | 8.24                 | •                                      | 437                        | 511                                  | A1                              | steel                               | steel                   | 42.0                      | 51.0                         | unk. | unk. | 15    | 15    | 1.00 | 1.00 | 2 3/4 | 1/2 | 13   | 1.00 | 2 1/2 | 3/8 |
| I           | 4A          | TB-1AF      | 1315-17                   | 1315-17                      | I.W.                                     | 6.44         | 10.1      | 14.44                                   | 15.76                | •                                      | 832                        | 778                                  | A1                              | steel                               | steel                   | 42.0                      | 50.0                         | unk. | unk. | 15    | 15    | 1.00 | 1.00 | 2 3/4 | 1/2 | 13   | 1.00 | 2 1/2 | 3/8 |
| I           | 4B          | TB-1AF      | 1315-17                   | 1315-17                      | I.W.                                     | 11.18        | 16.12     | 3.06                                    | 778                  | •                                      | 778                        | 778                                  | A1                              | steel                               | steel                   | 50.0                      | 50.0                         | unk. | unk. | 15    | 15    | 1.00 | 1.00 | 2 3/4 | 1/2 | 13   | 1.00 | 2 1/2 | 3/8 |
| I           | 5A          | TB-1AF      | 1315-17                   | 1315-17                      | I.W.                                     | 9.33         | 9.92      | 15.43                                   | 15.61                | •                                      | 832                        | 832                                  | A1                              | steel                               | steel                   | 42.0                      | 42.0                         | unk. | unk. | 10.5  | 10.5  | 1.00 | 1.00 | 2 3/4 | 1/2 | 13   | 1.00 | 2 1/2 | 3/8 |
| II          | AF-1        | TBP-AF      | 1012                      | 1012                         | I.W.-17                                  | 6.4          | 8.3       | 12.0                                    | 2.0                  | •                                      | 494                        | 778                                  | A1                              | steel                               | steel                   | 40.8                      | 15.0                         | 15.0 | 15.0 | 10.5  | 17.25 | 1.00 | 1.25 | 2 3/4 | 1/2 | 13   | 1.00 | 2 1/2 | 3/8 |
| II          | AF-2        | TB3-AF      | 1517                      | 1517                         | I.W.-17                                  | 10.3         | 6.4       | 16.3                                    | 15.0                 | •                                      | 778                        | 778                                  | A1                              | steel                               | steel                   | 50.0                      | 50.0                         | 15.0 | 15.0 | 17.25 | 15    | 1.00 | 1.25 | 2 3/4 | 1/2 | 13   | 1.25 | 2 3/4 | 1/2 |
| III         | TEST-1      | TB-2-AF     | 1012                      | 1012                         | I.W.-17                                  | 14.6         | 12.83     | 3.3/6.0++                               | 548                  | •                                      | 548                        | 548                                  | A1                              | steel                               | steel                   | 40.0                      | 13.0                         | 13.0 | 13.0 | 12    | 12    | 1.00 | 1.00 | 2 3/4 | 1/2 | 12   | 1.00 | 2 1/2 | 3/8 |
| III         | TEST-9      | TB-1-AF     | 1315-17                   | 1315-17                      | I.W.                                     | 9.5          | 16.7      | 3.3/6.7++                               | 950                  | •                                      | 950                        | 950                                  | A1                              | steel                               | steel                   | 55.0                      | 15.0                         | 15.0 | 15.0 | 15    | 15    | 1.00 | 1.00 | 2 3/4 | 1/2 | 13.5 | 1.00 | 2 3/4 | 1/2 |

+I.W. SIGNIFIES INTERNAL WELD

++ Anchor bolts are 3.3" high. The second dimension is the aluminum shard.

• Only mounting bolts remained.

\*\* In addition, 2.75 inch X 4.25 inch X 0.625 inch thick rectangular washers were also used.

\*\*\* Anchor bolt nuts should not be torqued over 200 ft-lbs.

Acceptance letter for series I dated January 12, 1989  
 Acceptance letter for series II dated January 24, 1989  
 Acceptance letter for series III dated May, 1990

Note 1. Series II/Test AF-1 also relates to the TB-2 base.  
 Note 2. All Series I tests also relate to the TB-1 base.

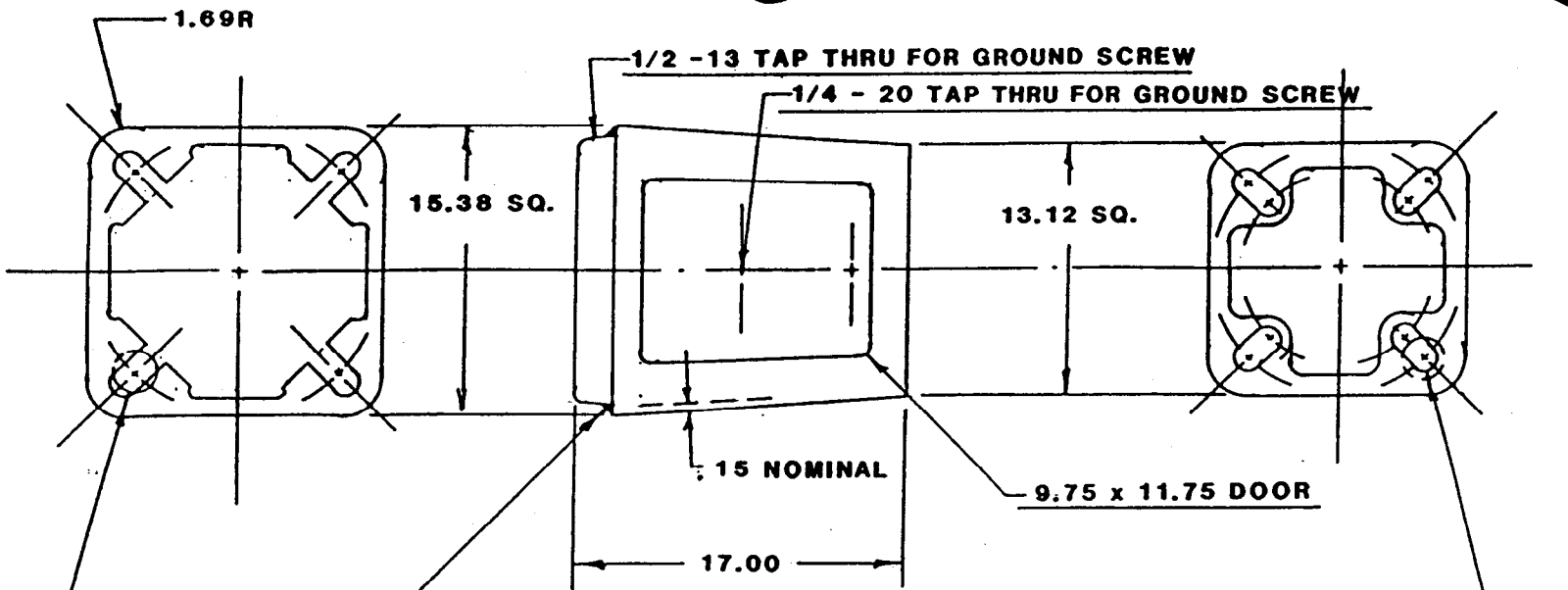

MIG 4043 WIRE 1/4" WITH APPROX. 5" OF WELD ON EACH OF THE ( 4 ) INTERNAL CORNERS

2 3/4 DIA. x 1 1/16 I.D. x 1/2 TK. STEEL WASHERS FOR 1" DIA. ANCHORAGE

OR 1 5/16 DIA. I.D. FOR 1 1/4 DIA. ANCHORAGE

4 PLS. EQ. SPACED ON 13.00 DIA. TO 15.00 DIA. BOTTOM GROUND B.C.

2 1/2 DIA. x 1 1/16 x 3/8 TK. OR 2 3/4 DIA. x 1 1/16 x 1/2 TK. STEEL WASHERS

4 PLS. EQ. SPACED ON 10.50 DIA. THRU 13.50 DIA. B.C.

DOOR SUPPLIED/BLANK OR LOGO IN ALUMINUM OR PLASTIC WITH OR WITHOUT HINGE  
ST'D 1/4 -20 S.S.HEX. SCREW OR VANDAL SCREW TO FIT YOUR SPECIFICATIONS

ALL WASHERS TO BE ZINC MECHANICAL COATED PER ASTM B 695 - 85 CLASS 50

356 T-6 ALUMINUM ALLOY / S.S. WHEELABRATED FINISH CHEMICAL AND PHY. CERTS TO BE SUPPLIED WITH EACH SHIPMENT

ADHESIVE BREAKAWAY AND CAUTION LABELS TO APPEAR  
ON INSIDE WALL OPPOSITE DOOR OPENING

|                    |                     |
|--------------------|---------------------|
| AKRON FOUNDRY CO.  |                     |
| 1985 AASHTO T-BASE |                     |
| 1-25-88            | TB1-AF 1315-17 I.W. |

**MATERIAL MELTED AND MANUFACTURED IN THE USA. CASTINGS PRODUCED IN THE USA.**

Enclosure 2, page 1 of 2

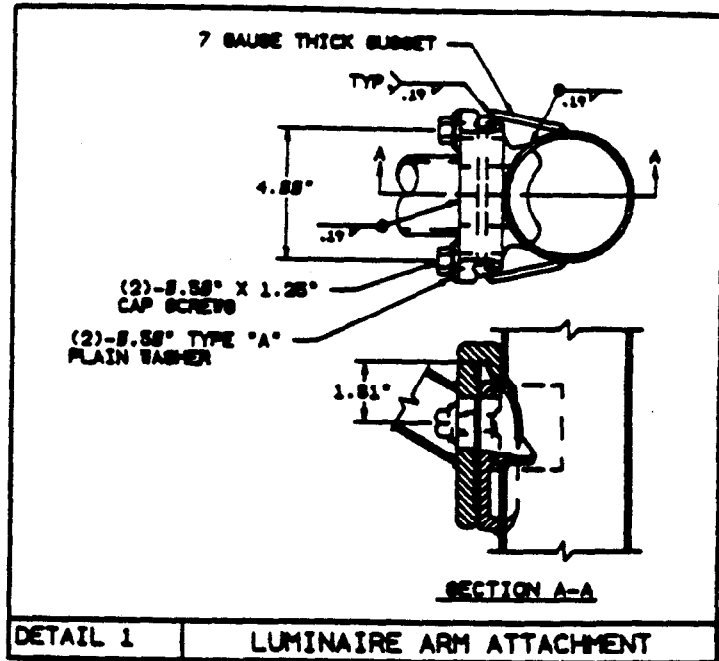
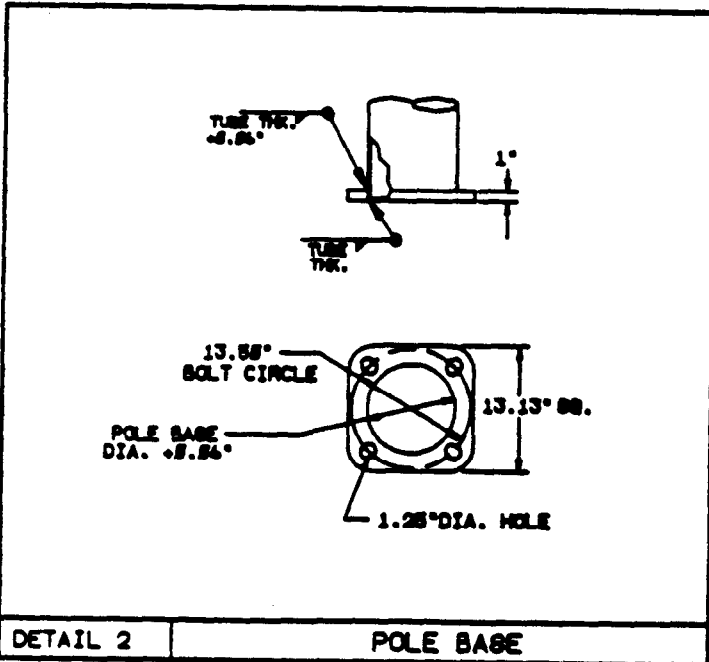
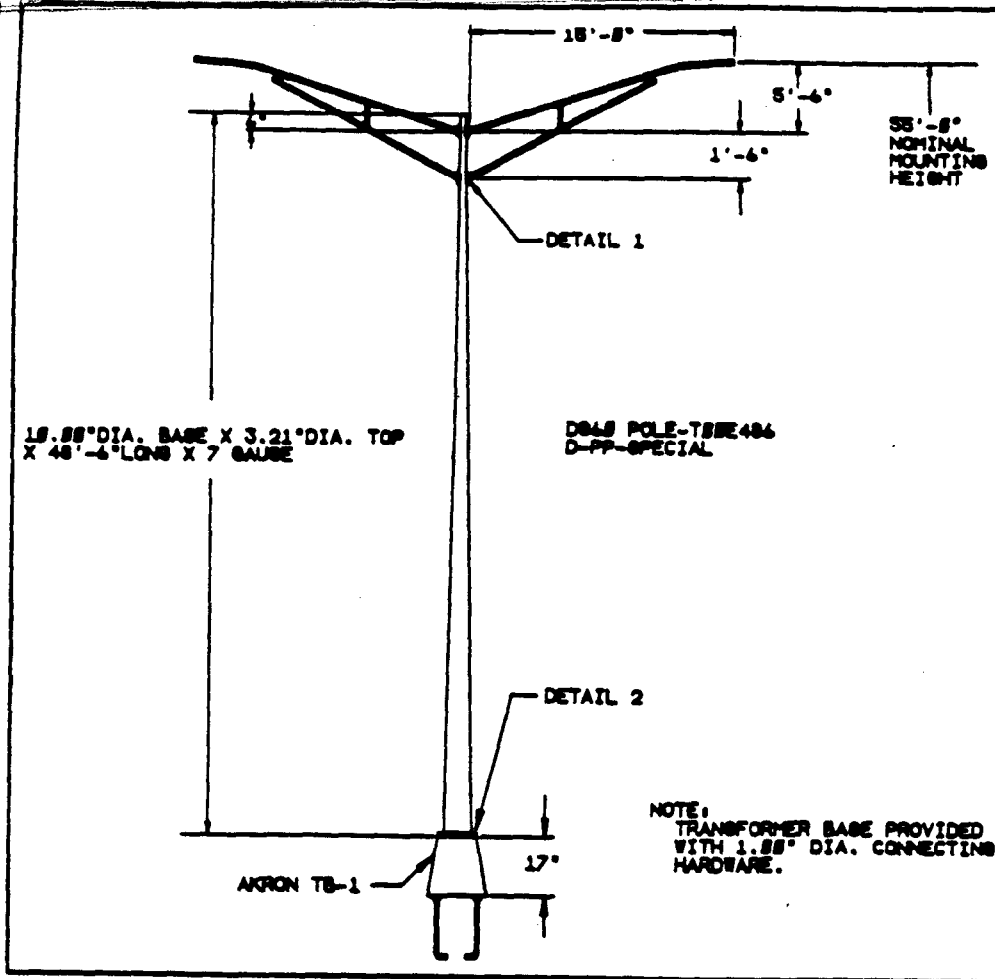

MATERIAL DATA

| COMPONENT                         | ASTM DESIGNATION | MIN. YIELD (KSI) | COMPONENT   | ASTM DESIGNATION | MIN. YIELD (KSI) |
|-----------------------------------|------------------|------------------|---|------------------|------------------|
| POLE SHAFT                        | A575 GR A        | 55               | PRIME PAINT-OUTSIDE SURFACES ONLY PER VALMONT SPEC. NO. F73 | NA               | NA               |
| ARM SHAFT-2.38" O.D. X .164" WALL |                  | 36               |   |                  |                  |
| ARM STRUTS                        | HPM8             |                  |   |                  |                  |
| ARM SIMPLEX ATTACHMENTS           | A27 6068-38      |                  |   |                  |                  |
| SIMPLEX PLATE SUBSETS             | HPM8             |                  |   |                  |                  |
| BASE PLATE                        | A36              | 36               |   |                  |                  |

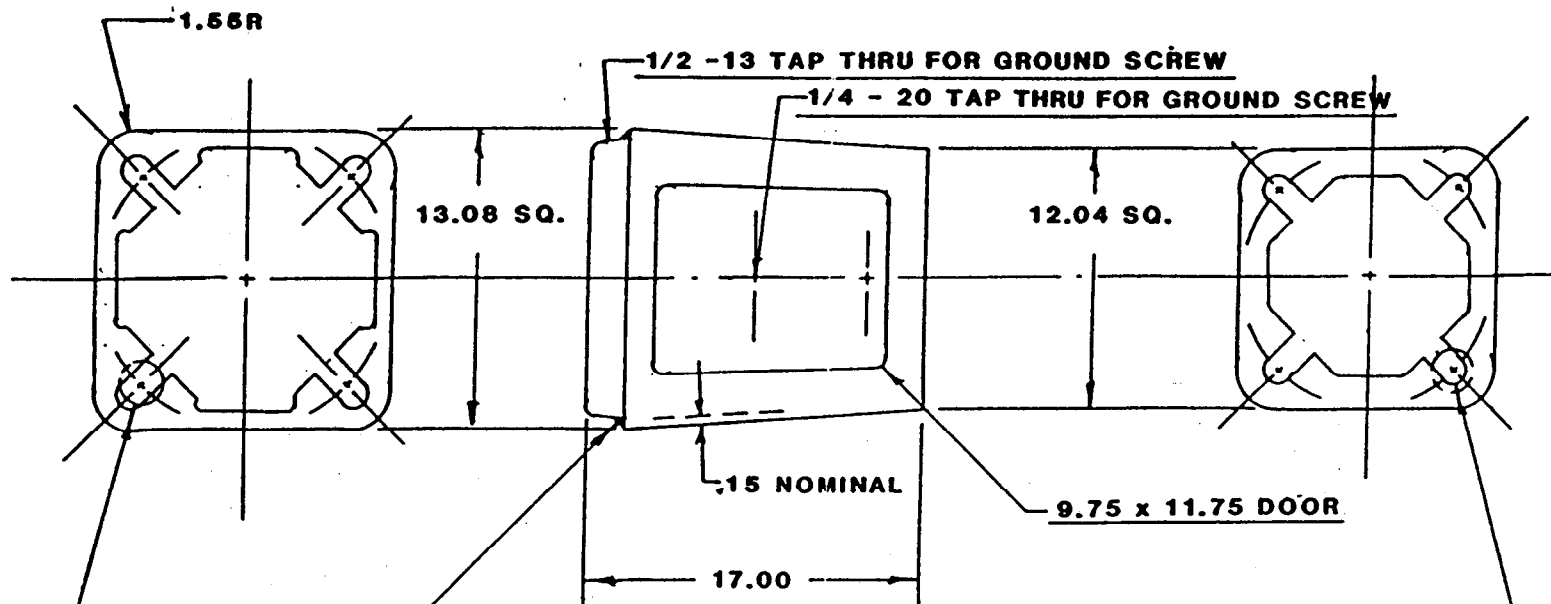

MIG 4043 WIRE 1/4" WITH APPROX. 5" OF WELD ON EACH OF THE ( 4 ) INTERNAL CORNERS

2 3/4 DIA. x 1 1/16 I.D. x 1/2 TK. STEEL WASHERS FOR 1" DIA. ANCHORAGE  
4 PLS. EQ. SPACED ON 10.00 DIA. THRU 12.00 DIA. GROUND B.C.

2 1/2 DIA. x 1 1/16 I.D. x 3/8 TK. OR 2 3/4 DIA. x 1 1/16 I.D. x 1/2 TK. STEEL WASHERS  
4 PLS. EQ. SPACED ON 10.00 DIA. THRU 12.00 DIA. B.C.

DOOR SUPPLIED/BLANK OR LOGO IN ALUMINUM OR PLASTIC WITH OR WITHOUT HINGE  
STD 1/4 - 20 S.S.HEX. SCREW OR VANDAL SCREW TO FIT YOUR SPECIFICATIONS

ALL WASHERS TO BE ZINC MECHANICAL COATED PER ASTM B 695 - 85 CLASS 50

356 T-6 ALUMINUM ALLOY / S.S. WHEELABRATED FINISH CHEMICAL AND PHY. CERTS TO BE SUPPLIED WITH EACH SHIPMENT

ADHESIVE BREAKAWAY AND CAUTION LABELS TO APPEAR  
ON INSIDE WALL OPPOSITE DOOR OPENING

|                    |                         |
|--------------------|-------------------------|
| AKRON FOUNDRY CO.  |                         |
| 1985 AASHTO T-BASE |                         |
| 1-25-88            | TB2 - AF 1012 - 17 I.W. |

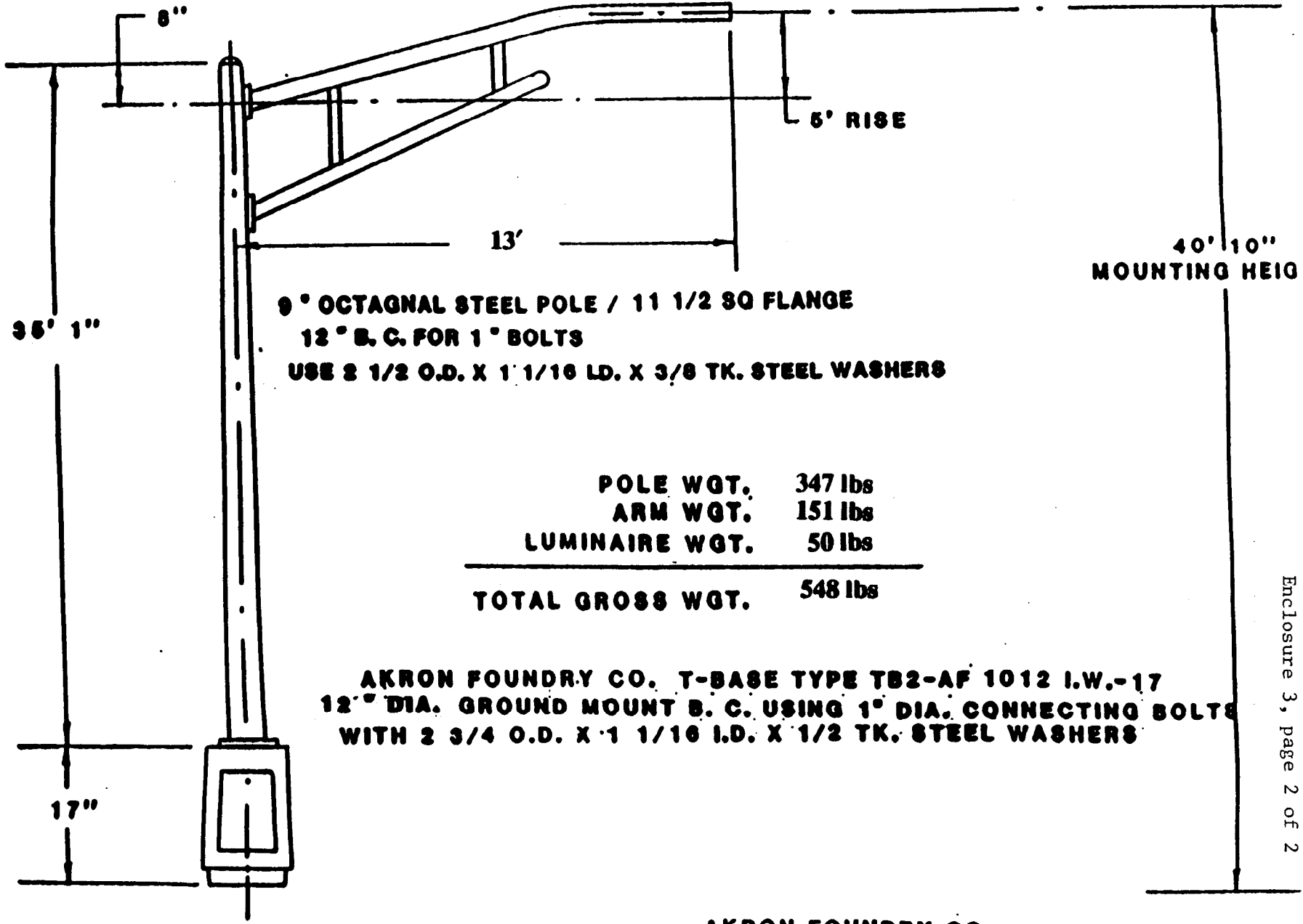

**9" OCTAGNAL STEEL POLE / 11 1/2 SQ FLANGE**  
**12" B. C. FOR 1" BOLTS**  
**USE 2 1/2 O.D. X 1 1/16 LD. X 3/8 TK. STEEL WASHERS**

|                |         |
|----------------|---------|
| POLE WGT.      | 347 lbs |
| ARM WGT.       | 151 lbs |
| LUMINAIRE WGT. | 50 lbs  |

---

**TOTAL GROSS WGT. 548 lbs**

**AKRON FOUNDRY CO. T-BASE TYPE TB2-AF 1012 I.W.-17**  
**12" DIA. GROUND MOUNT B. C. USING 1" DIA. CONNECTING BOLTS**  
**WITH 2 3/4 O.D. X 1 1/16 I.D. X 1/2 TK. STEEL WASHERS**

**AKRON FOUNDRY CO.**  
**TB2-AF 1012 I.W.-17**

**7-10-89**

Enclosure 3, page 2 of 2