



U.S. Department  
of Transportation

Federal Highway  
Administration

400 Seventh St., S.W.  
Washington, D.C. 20590

August 4, 1995

Refer to: HNG-14

Mr. Jay Mullen  
Component Products, Inc.  
296 Carlton Drive  
Carol Stream, Illinois 60188

Dear Mr. Mullen:

Thank you for your July 26 letter requesting Federal Highway Administration's (FHWA) acceptance of a cast aluminum breakaway base CPI-BAS-1 for traffic signal supports distributed by your company. Your letter was accompanied by affidavits from representatives of Permocast Inc., of Henryetta, Oklahoma, the manufacturers of the base. These affidavits attest to the fact that the bases that they manufactured and sold to Pelco Products, Inc., until November 1991, and continue to sell to you are the same bases that were crash tested at Texas Transportation Institute (TTI). These bases have been approved and used by the State of Texas according to the affidavits. The FHWA Office of Engineering, however, has not had an opportunity to review the crash tests of this base until now.

Your letter was accompanied by two reports of the TTI crash tests dated March 1989, on specimens of the cast aluminum base supporting a 114.3-mm (4½-inch) outside-diameter (nominal 4-inch) steel support pipe. The base is made from ASTM B26 Aluminum 319 alloy, with no tempering following casting and is shown in the enclosed drawing titled "SQ ALUM BASE 319 ALLOY - CPI MODEL BAS-1" drawn February 13, 1981. The top and bottom of the base are also machined after casting to result in a finished overall height of approximately 385 mm (15 1/8 inches.)

Requirements for breakaway supports are found in the American Association of State Highway and Transportation Officials (AASHTO) Standard Specifications for Structural Supports for Highway Signs, Luminaires and Traffic Signals. Testing guidelines followed in these tests were those found in the National Cooperative Highway Research Program (NCHRP) Report 230, "Recommended Procedures for the Safety Performance Evaluation of Highway Appurtenances" which, for breakaway supports, are an acceptable alternative to the currently recognized guidelines in the NCHRP Report 350, "Recommended Procedures for the Safety Performance Evaluation of Highway Features." A summary of the test data is shown below and a drawing of the test installation is enclosed.

Test Number	9429J-1	9429J-2
Base Designation	CPI BAS 1	CPI BAS 1
Bolt Circle Diameter, mm (in) Test Article Mass, kg (wt, lbs)	356 (14.0) approx. 86 (190) *	356 (14.0) approx. 86 (190)*
Mounting Height, m (ft) Vehicle Mass, kg (weight, lbs)	1.52 (5.0) to sign bottom 817 (1800)	1.52 (5.0) to sign bottom 817 (1800)
Test Speed, km/h (mph)	32.9 (20.5 )	98.7 (61.3)
Occupant Impact Speed m/s (fps)	4.3 (13.9)	3.4 (11.2)
Stub Height, mm (in)	**	**

\*The mass of the test articles were not recorded by TTI. This estimate includes the mass of the base, pole, sign panel, and flasher beacon.

\*\* The highest objects remaining at the foundation were the anchor bolts, which were installed to be less than the 100-mm limit.

The results of these tests meet the change in velocity and stub height requirements adopted by AASHTO and the FHWA. Therefore, the tested aluminum breakaway base described above is acceptable for use on the National Highway System (NHS), under conditions comparable to those evaluated, when selected by a highway agency. The traffic signal supports, including pole, signal head(s), pedestrian signal(s), etc., up to a mass of 100 kg (220 pounds) may be used with the CPI-BAS-1 breakaway base.

Our acceptance is limited to the breakaway characteristics of the system and does not cover its structural features. Presumably, you will supply potential users with sufficient information on structural design and installation requirements to ensure proper performance. We anticipate that the States will require certification from Component Products, Inc., that the hardware furnished has essentially the same chemistry, mechanical properties, and geometry as those used in the tests, and that they will meet the FHWA change in velocity requirements.

Sincerely yours,

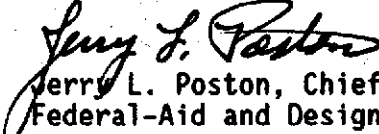
  
Jerry L. Poston, Chief  
Federal-Aid and Design Division

2 Enclosures

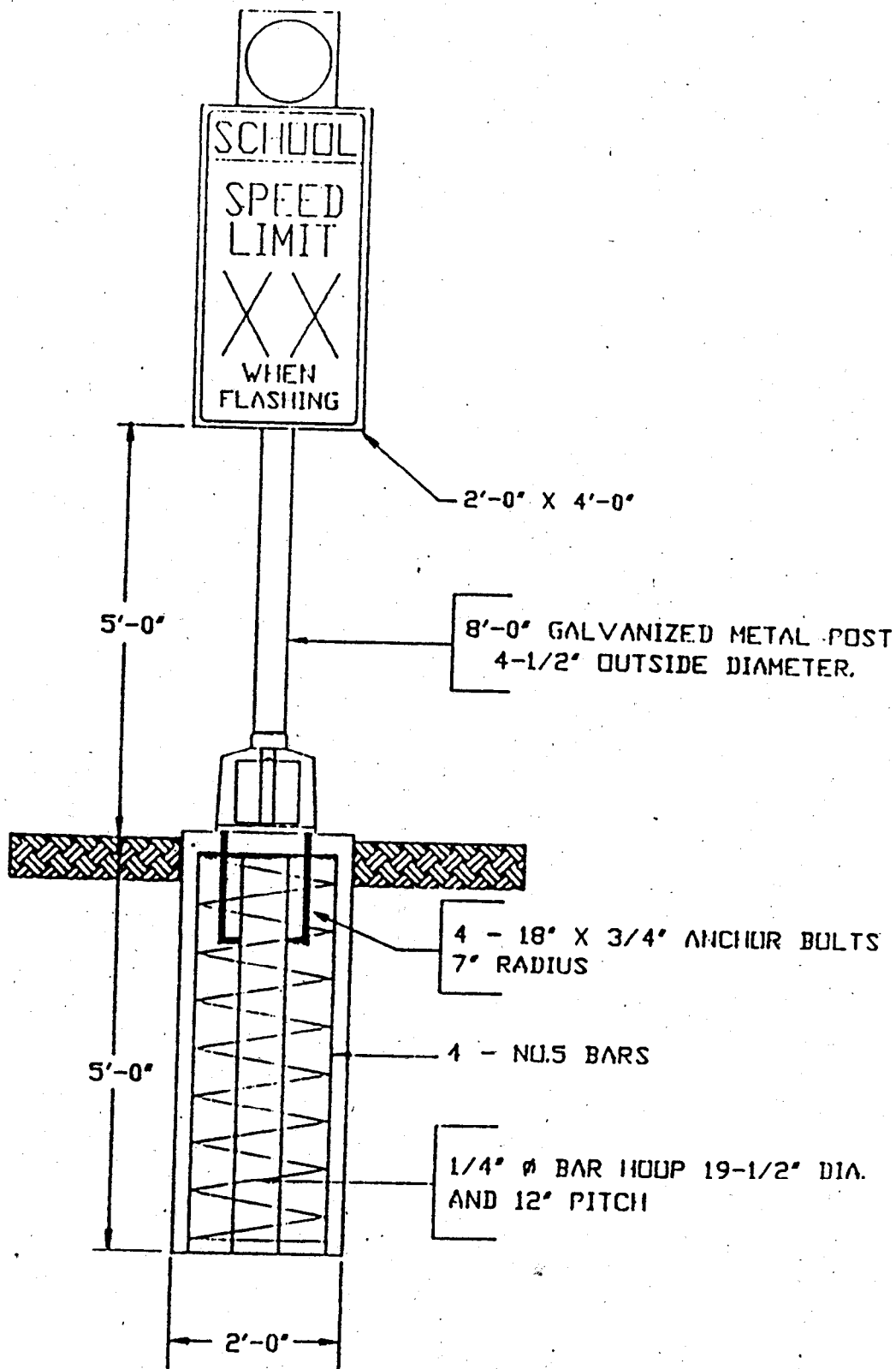
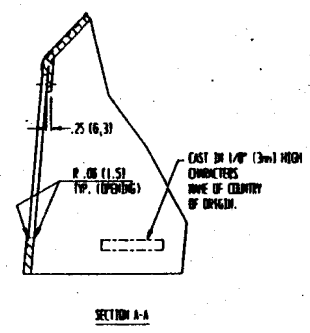
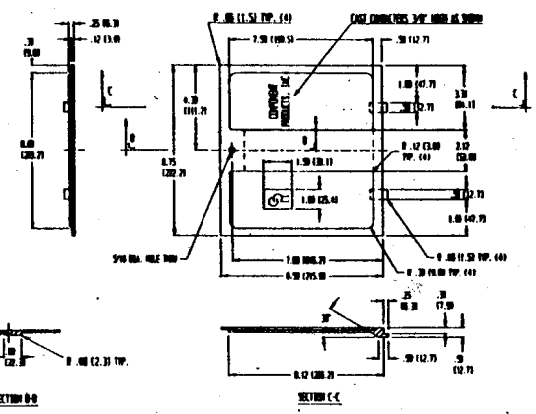
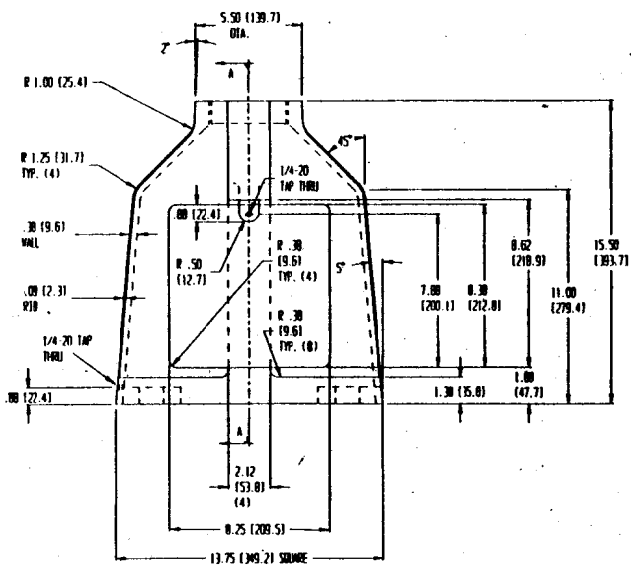
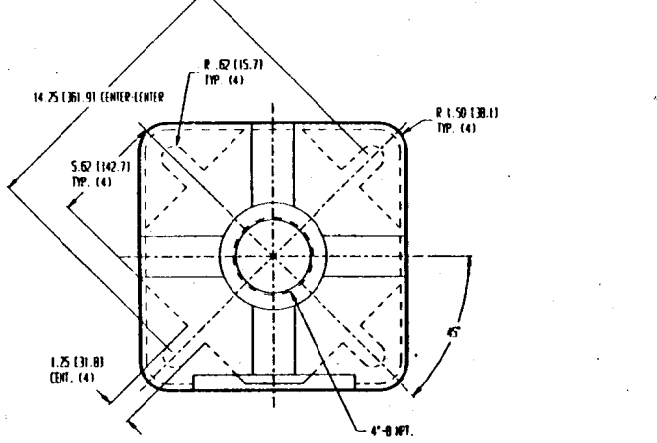

Figure 1. Details of sign installation for test 9429J-2.



NOTE: DIMENSIONS IN SQUARE BRACKETS ARE IN MILLIMETERS.

WELDER SIGNATURE AND THE DIMENSIONS ARE IN INCHES			
DATE	BY		

CDC ORDER #100  
DISPOSITION # 100-26 S-14894D

30 ALLIANCE WAY ALLEY  
CP MARIETTA, GA 30151  
W.A.R. 1-1

MANUFACTURED BY  
FERNICAST, INC.  
HENRYETTA, GA  
DRAWN FEB. 11, 1961